



# “FTS445” Steel Fabricated Tapping Sleeve

**Material Specifications**

**Body and Outlet Nozzle:** Carbon steel, A-36 or equal. Also available with type 304 stainless steel (style STS445)

**Flange:** Carbon steel, A-36 or equal. AWWA Class "D" plate flange, ANSI CLS 150 drilling, proper recessing for tapping valves. Will accommodate tapping flanges per MSS SP-60.

**Test Plug:** 3/4" NPT type 304 stainless steel test plug.

**Coatings:** Romac shopcoat for corrosion protection in transit. Optional fusion epoxy 8-12 mil. lined and coated. Edges and ID masked where weld is required. Romac packages sleeves to protect coating.

## Fabricated Tapping Sleeve for Weld-on Outlets

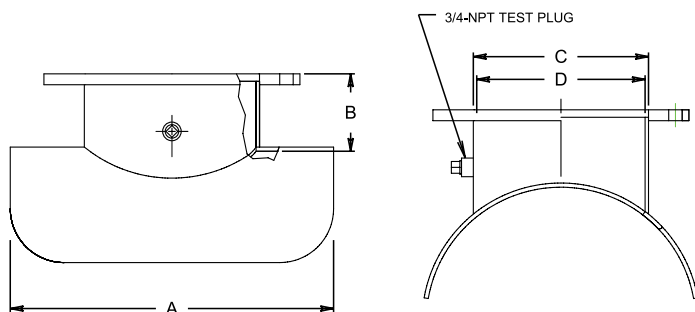

FLANGE SIZE	DIMENSIONS				MIN. PIPE DIAMETER
	A	B	C	D	
4"	9.0	5.18	5.03	4.73	6.00
6"	12.0	5.18	7.03	6.73	8.00
8"	16.0	5.18	9.03	8.73	10.00
10"	20.0	5.50	11.03	10.73	12.00
12"	22.0	5.75	13.03	12.73	14.00
14" *	24.0	6.00	15.03	14.73	16.00
16" *	29.0	6.00	17.03	16.73	20.00
18" *	32.0	6.00	19.03	18.73	22.00
20" *	35.0	6.00	21.03	20.73	24.00
24" *	42.0	6.63	25.03	24.73	36.00

Sleeves designed for a minimum pipe wall thickness of 0.25" and a minimum pipe material yield strength of 36 ksi will be collar style.

Size on size sleeves, and sleeves for thinner or lower strength pipe will require full wrap style sleeve (see illustration below).

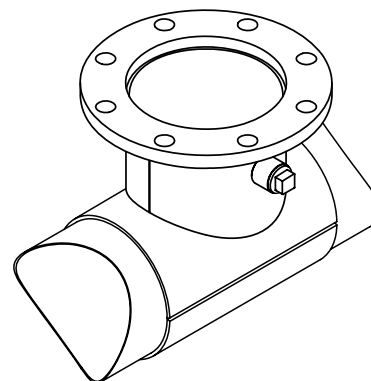

\* Please specify tapping valve manufacturer, and flange dimensions for flange sizes larger than 12 inches.

Larger sizes and outlets available.

All prices POA



No Cancel, No Return Item.