

REVISIONS			
REV	DESCRIPTION	DATE	APPROVED
1	CHANGED NOTES TO REFLECT STD EPOXY & ADDED STAINLESS STEEL AVAILABILITY	31/Jan/03	NST III
2	ADDED O-RING GASKET DIAMETER "G" TOTABLE	29/Mar/05	NST III

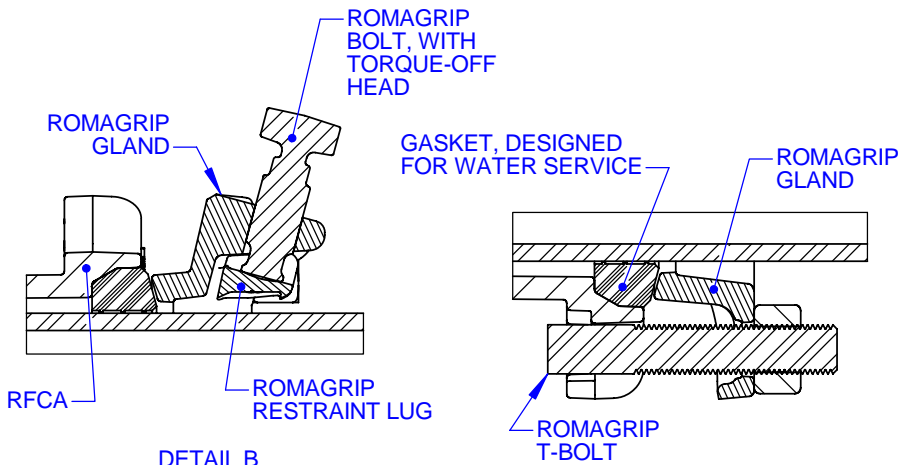
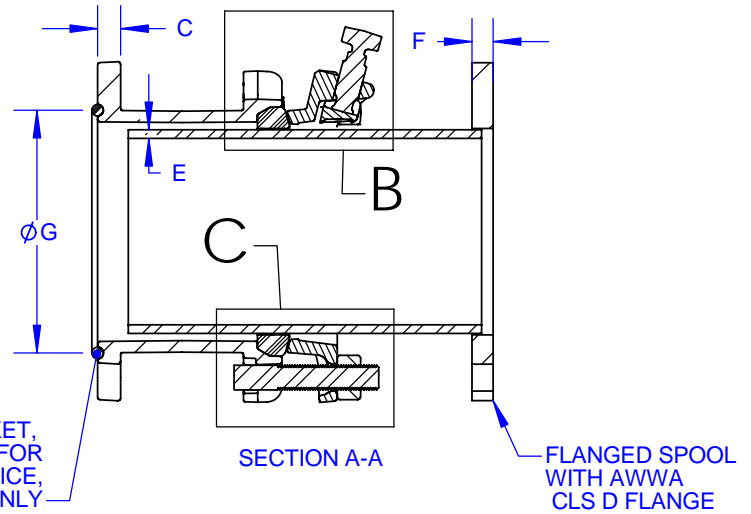
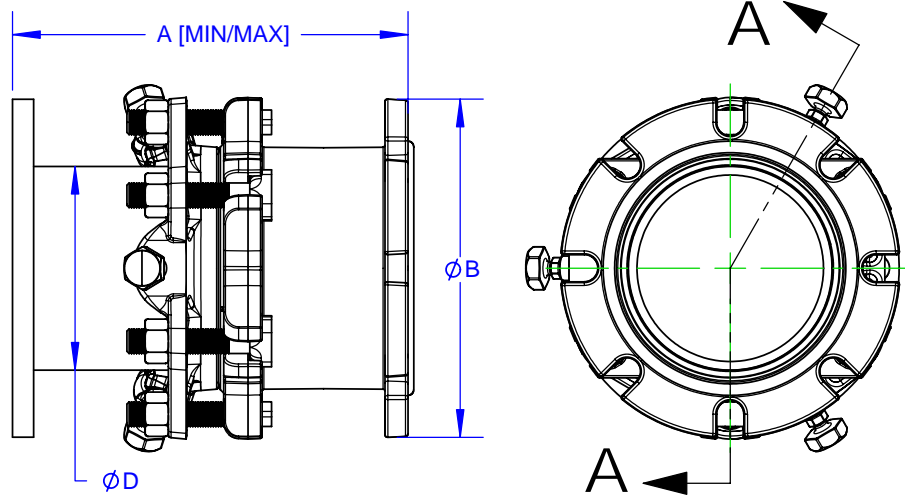

NOM SIZE	DIMENSIONS						MAX DEF. (DEG)	T-BOLTS			FLANGED SPOOL			RFCA	WGT (LBS)
	LENGTH "A"			FLG OD "B"	FCA FLG THK "C"	QTY		SIZE	LENGTH	OD "D"	PIPE THK "E"	FLG THK "F"	GSKT DIA "G"		
	NOM.	MIN	MAX												
3	11.50	10.00	13.00	7.5	0.75	2.0	4	5/8"	3.75	3.50	0.22	0.63	4.66	33	
4	12.75	11.00	14.50	9.0	0.75	3.5	4	3/4"	4.25	4.50	0.24	0.63	6.00	46	
6	13.50	11.50	15.50	11.0	0.75	3.5	6	3/4"	4.25	6.63	0.28	0.69	7.90	68	
8	13.50	11.50	15.50	13.5	0.75	3.3	6	3/4"	4.25	8.63	0.32	0.69	10.00	94	
10	14.75	12.50	17.00	16.0	0.75	3.0	8	3/4"	4.25	10.75	0.37	0.69	12.40	143	
12	14.75	12.50	17.00	19.0	0.81	3.0	8	3/4"	4.25	12.75	0.38	0.81	15.12	193	
14	19.25	16.75	21.75	21.0	1.38	2.0	10	3/4"	4.50	15.30	0.38	0.94	-	297	
16	19.25	16.75	21.75	23.5	1.44	2.0	12	3/4"	4.50	17.40	0.38	1.00	-	352	
18	20.25	17.75	22.75	25.0	1.45	1.5	12	3/4"	4.50	19.50	0.38	1.06	-	390	
20	20.25	17.75	22.75	27.5	1.47	1.5	14	3/4"	4.50	21.60	0.38	1.13	-	457	
24	21.25	18.75	23.75	32.0	1.50	1.5	16	3/4"	5.00	25.80	0.38	1.25	-	569	

- NOTES:
- NSF 61 CERTIFIED COATING: FUSION BONDED EPOXY IS STANDARD. OTHER COATINGS AVAILABLE UPON REQUEST.
 - CUSTOMER MUST CONFIRM LENGTH OF ASSEMBLY TOLERANCE "A".
 - PRESSURE RATED UP TO FLANGES PROVIDED. 3"-12" AWWA CLS D 175 PSIG WORKING, 263 PSIG TEST. 14"-24" AWWA CLS D 150 PSIG WORKING, 225 PSIG TEST. HIGHER PRESSURE RATINGS AND FLANGES AVAILABLE.
 - ROMAC DJ405 DISMANTLING JOINT WILL ALLOW DEFLECTION. SEE TABLE FOR VALUES.
 - T-BOLTS PER AWWA C111. STAINLESS STEEL FASTENERS AVAILABLE UPON REQUEST.

THIS DRAWING CONTAINS CONFIDENTIAL PROPRIETARY INFORMATION AND IS THE PROPERTY OF ROMAC IND., INC. IT'S TO BE USED ONLY FOR THE PURPOSE FOR WHICH IT'S SUBMITTED AND SHALL NOT HAVE ITS INFORMATION DISCLOSED OR REPRODUCED IN WHOLE OR IN PART FOR ANY PURPOSE WITHOUT PRIOR WRITTEN PERMISSION OF ROMAC IND., INC.

SIGNATURES		DATE			ROMAC IND. INC., SEATTLE, WA	
DRAWN: NIELS THOGERSEN III		27 DEC 2002			TITLE: DISMANTLING JOINT DJ405 3"- 24"	
CHECKED: GEORGE DENISON		31 DEC 2002				
ISSUED:						
ENGRG:						
MATERIAL: ASTM A536 ASTM A36				SIZE: A	DWG. NO: B2128-A	REV. NO: 2
				SCALE: NTS	SHEET 1 OF 1	