

B2704-A

NOM. SIZE	DEFL. (deg)	RG		PRESS. (PSIG)		LENGTH		BOLTS			
		MAX A	GLD OD B	WKG	TEST	C	D	E	F	G	
12	10.0	19.5	18.1	350	500	8.10	13.90	3/4	18.00	8	
14	4.0	22.0	20.6	350	500	8.10	13.90	3/4	18.00	10	
16	4.0	24.1	22.9	350	500	8.10	14.10	3/4	18.00	12	
18	3.0	26.3	25.1	250	400	8.10	14.10	3/4	18.00	12	
20	3.0	28.4	27.4	250	400	8.10	14.30	3/4	18.00	14	
24	3.0	32.6	31.9	250	400	8.10	14.50	3/4	18.00	16	
30	2.0	43.5	39.5	250	400	8.60	16.60	1	22.50	20	
36	2.0	50.0	46.4	250	400	8.60	17.40	1	22.50	24	
42	2.0	56.3	53.5	250	400	8.60	18.60	1 1/4	25.00	28	
48	2.0	62.6	60.4	250	400	8.60	19.40	1 1/4	25.00	32	

REVISIONS			
REV.	DESCRIPTION	DATE	APPROVED
0	INITIAL RELEASE	2/17/2006	NST III
1	48" LENGTH "F" WAS 21.9	6/20/2007	NST III
2	NOM SIZE 14-20" WAS 6° DEFLECTION NOM SIZE 24-48" WAS 4° DEFLECTION	4/21/2009	PNN

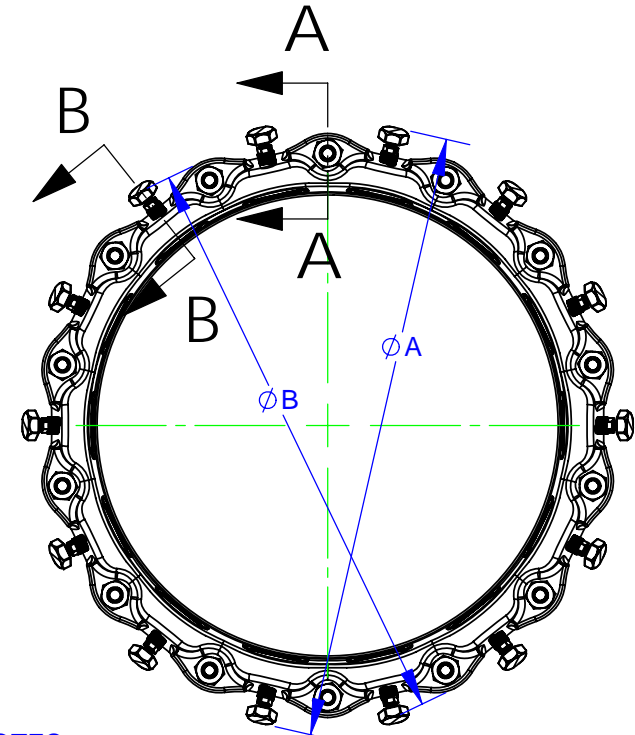
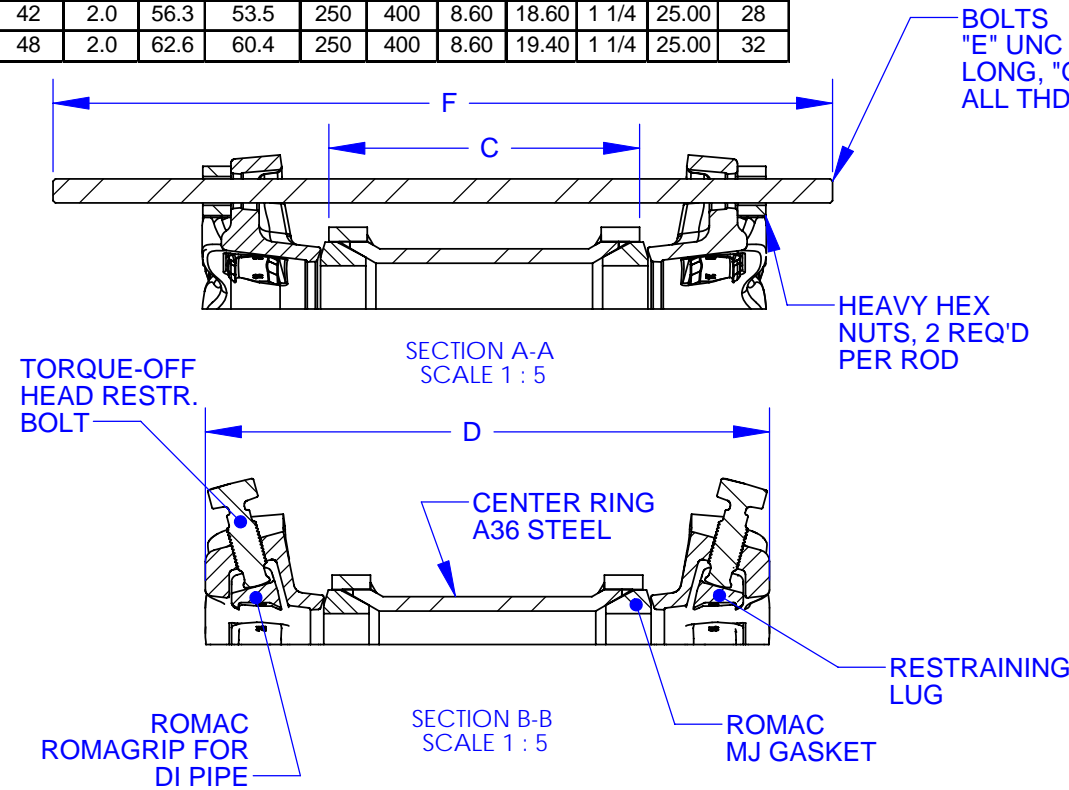

- NOTES
1. COATING: SHOPCOAT, FUSION BONDED EPOXY AVAILABLE.
 2. FASTENERS: ASTM A193 GR B7 (STEEL) STAINLESS STEEL GR 304 AND 316 AVAILABLE.
 3. MATERIAL: DUCTILE IRON AND A36 STEEL
 4. MINIMUM PIPE INSERTION IS 2.5" PAST THE EDGE OF THE CENTER RING.

<p>PROPRIETARY NOTICE</p> <p>THIS DRAWING CONTAINS CONFIDENTIAL PROPRIETARY INFORMATION AND IS THE PROPERTY OF ROMAC IND., INC. IT IS TO BE USED ONLY FOR THE PURPOSE FOR WHICH IT WAS SUBMITTED AND SHALL NOT HAVE ITS INFORMATION DISCLOSED OR REPRODUCED IN WHOLE OR IN PART FOR ANY PURPOSE WITHOUT PRIOR WRITTEN PERMISSION OF ROMAC IND., INC.</p>	<p>UNLESS OTHERWISE SPECIFIED</p> <p>DIMENSIONS ARE IN INCHES</p> <p>TOLERANCES ARE ON: 1 PL DECIMALS ± .060 2 PL DECIMALS ± .030 3 PL DECIMALS ± .010 ANGLES ± 1° FRACTIONS ± 1/64</p>	<p>SIGNATURES</p> <p>DRAWN</p> <p>CHECKED</p> <p>APPROVAL ORGANIZATIONS ENGINEERING</p>	<p>ROMAC INDUSTRIES INC., BOTHELL, WA</p> <p>TITLE</p> <p>400RG - 12" - 48" DUCTILE IRON PIPE</p>	<p>DWG. NO.</p> <p>B2704-A</p>	<p>SIZE</p> <p>A</p>	<p>REV. NO.</p> <p>2</p>	<p>SCALE</p> <p>NTS</p>	<p>SHEET</p> <p>1 OF 1</p>