

INSTALLATION INSTRUCTIONS

Read installation instructions first before installing. Check parts to ensure that no damage has occurred during transit and that no parts are missing. Also check the diameter of the pipe and the range marked on the saddle to ensure you have the proper size.

101S/101N & 202S/202N Ductile Iron Service Saddles

For PVC pipe, choose the saddle that fits the pipe OD closest to the top of the saddle's OD range

Step 1 • Check the saddle parts to insure that no damage has occurred during transit and that no parts are missing.

Step 2 • Check the diameter of the pipe and the range marked on the saddle to insure you are using the correct size saddle.

Step 3 • Thoroughly clean the pipe surface that will be covered by the saddle. A suitable gasket lubricant should be used on rough surface pipe (Iron and A/C) to assure proper seal.

Step 4 • Back off nut to the end of the bolt. Remove strap(s) from saddle body.

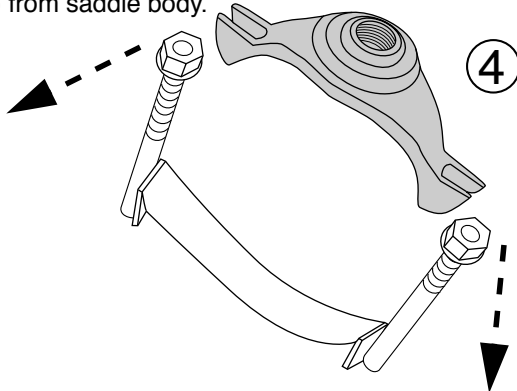

Step 5 • Position the saddle body on the pipe such that the outlet is in the correct location.

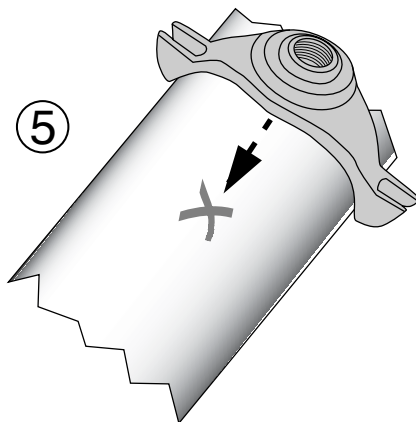

Step 6 • Install strap(s) on saddle body, and tighten finger tight. Make sure the gasket has seated itself flat onto the pipe face.

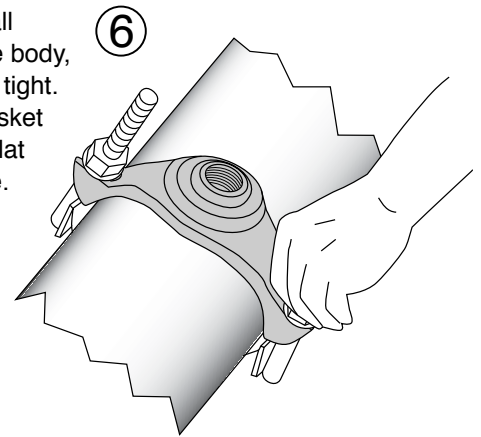

Step 7 • Tighten all nuts evenly in 20 ft-lbs. increments. Use a wrench with at least a 12 inch handle.

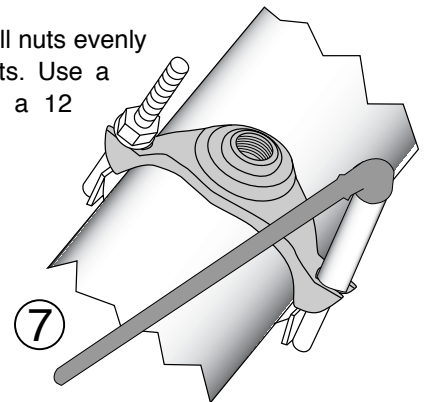

Note:

35 ft-lbs. torque = 12" wrench w/35 lbs. force

45 ft-lbs. torque = 12" wrench w/45 lbs. force

Pipe Material	Size	Torque (ft-lbs.)
PVC	1 1/2" - 22"	30-40
Rigid (D.I., A/C, Steel)	1 1/2" - 8"	40-50
PVC	24" - 30"	50-60
Rigid (D.I., A/C, Steel)	10" - 30"	60-75

Pressure test before tapping.

Backfill and compact carefully around saddle and service line.

101S/101N & 202S/202N Ductile Iron Service Saddles

PRECAUTIONS

1. Check diameter of pipe to make sure you are using correctly sized saddle.
2. Clean pipe to remove as much dirt and corrosion as possible from the surface.
3. Make sure no foreign material comes between the gasket and the pipe as the nuts are being tightened.
4. Avoid loose fitting wrenches, or wrenches too short to achieve proper torque on the nuts.
5. Keep threads free of foreign material to facilitate tightening.
6. Bolts are often not tightened enough when a torque wrench is not used, Take extra care in this situation to make sure that proper tightening occurs.
8. Pressure test for leaks before backfilling.
9. Backfill and compact carefully around saddle.
10. When reinstalling parts with stainless steel hardware there may be a loss in pressure holding ability due to worn or damaged threads during the original installation

COMMON INSTALLATION PROBLEMS

1. Bolts are not tightened to the proper torque.
2. Rocks or debris between pipe and gasket.
3. Dirt on threads of bolts or nuts.
4. Not properly supporting the branch pipe.
5. Not using the proper sized saddle for PVC pipe.
6. Improper backfilling around branch pipe.