



INSTALLATION INSTRUCTIONS

Read installation instructions first before installing. Check parts to ensure that no damage has occurred during transit and that no parts are missing. Also check the diameter of the pipe and the range marked on the clamp to ensure you have the proper size.

LIMITATIONS: For product limitations see reverse side. For more detailed information see the HDPE Products section of the Romac Product Catalog, or phone Romac Engineering Department at 1-800-426-9341.

Style 305-H Stainless Steel Service Saddle for HDPE Pipe

Spring Washers **must** be installed in these configurations

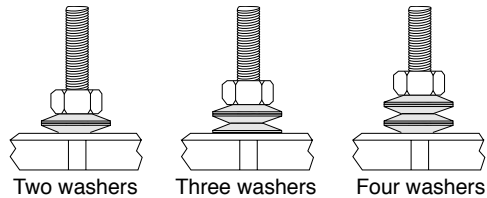

Step 1 • Thoroughly clean pipe surface that will be covered by the saddle.

Step 2 • Back off nut to the end of the bolt – DO NOT REMOVE. Separate saddle sections. Place outlet half of saddle on pipe and move into position.

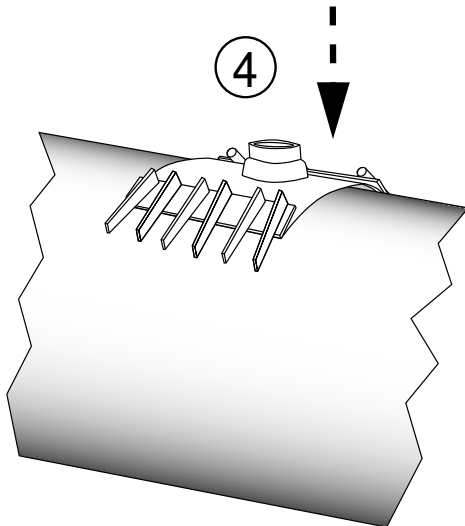

Step 3 • Place the other section in position so that bolts are in alignment for assembly and tightening.

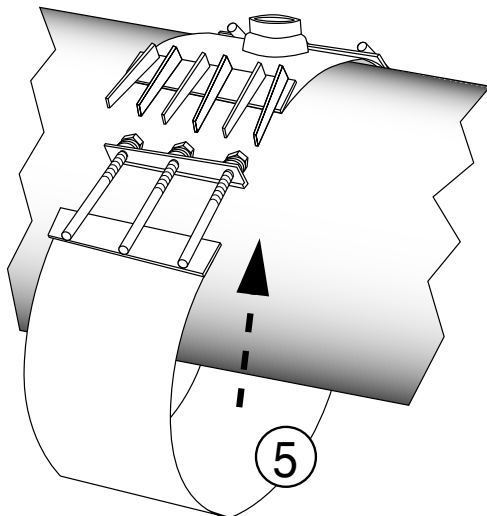

Step 4 • Slide lifter bar up the receiver lug profile and snap into place over the sidebar edge. Make sure the gasket has seated itself flat onto the pipe face.

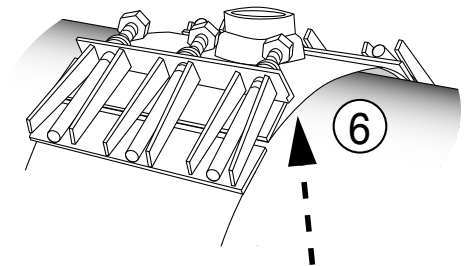

Step 5 • Tighten all nuts evenly in 15-20 ft-lb. increments. Alternate from one side to the other to equalize the gap between sections. Use a wrench with at least a 12 inch handle.

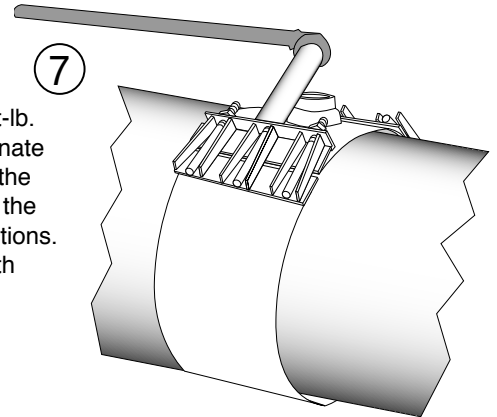

Nom. Pipe Diameter	Torque Min.
All sizes	75 ft-lbs.

Note:
75 ft-lbs. torque = 12" wrench w/75 lbs. force

Wait 10 minutes and then re-tighten to proper torque.

Pressure test before tapping.

Backfill and compact carefully around saddle and service line.

INSTALLATION INSTRUCTIONS

Style 305-H

PRECAUTIONS

1. Check diameter of pipe to make sure you are using the correctly sized saddle.
2. Clean pipe to remove as much dirt and corrosion as possible from the surface.
3. Make sure no foreign materials stick to the gasket as it is brought around the pipe, nor become lodged between gasket and pipe as nuts are tightened.
4. Avoid loose fitting wrenches, or wrenches too short to achieve proper torque.
5. Keep threads free of foreign material to facilitate tightening.
6. Bolts are often not tightened enough when a torque wrench is not used. Take extra care in this situation to make sure proper tightening occurs.
7. Always pressure test for leaks before backfilling.
8. Backfill and compact carefully around clamp.

COMMON INSTALLATION PROBLEMS

1. Bolts are not tightened to the proper torque.
2. Rocks or debris cutting gasket.
3. Dirt on threads of bolts or nuts.
4. Installing in the heat of the day.

PRODUCT LIMITATIONS

High Density Polyethylene Pipe (HDPE) has a lower modulus of elasticity and higher coefficient of thermal expansion than other pipe materials. These properties cause HDPE pipe to expand and contract much more from changes in temperature and/or pressure than other piping materials. Because of these and other properties, great care must be taken when installing conventional fitting on HDPE.

This product has been provided with the proper number of spring washers for the conditions described in the following limitations.

HDPE LIMITATIONS:

- Pipe must be manufactured in accordance with AWWA Standard C906-90.
- Operating temperatures are limited to 85° F maximum and 32° F minimum.
- Operating pressure is limited to 150 psi or the rating of the pipe, whichever is less.
- Pipe systems must be designed to compensate for pipe movement so as to prevent fittings from migrating or rotating on the pipe.
- Products are intended for use in underground service only.
- Products are not to be used on pressurized HDPE pipe with an SDR greater than 26.



ROMAC CANNOT WARRANT PRODUCTS USED IN APPLICATIONS THAT ARE OUTSIDE ONE OR MORE OF THESE LIMITATIONS. CONTACT ROMAC'S ENGINEERING DEPARTMENT AT 1-800-426-9341 IF YOU HAVE QUESTIONS ABOUT THE USE OF OUR PRODUCTS ON HDPE PIPE.

HDPE PRECAUTIONS:

Try always to install fittings when pipe is at its coldest.

Be sure that spring washers are stacked properly (see drawing at right).

This product is designed for a 53° F temperature range maximum.

