



INSTALLATION INSTRUCTIONS

Read installation instructions first before installing. Check parts to ensure that no damage has occurred during transit and that no parts are missing. Also check the diameter of the pipe and the range marked on the clamp to ensure you have the proper size.

Style 416 & 418 Bell Joint Leak Clamp

1

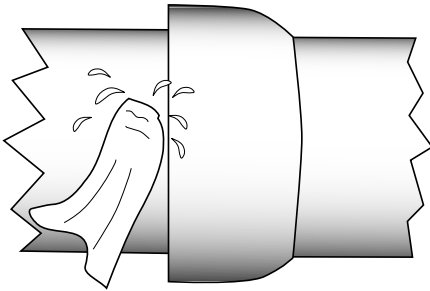

Step 1 • Clean the pipe surface adjacent to the entrance of the bell. Clean all around the pipe on the face of the bell where the gasket will contact.

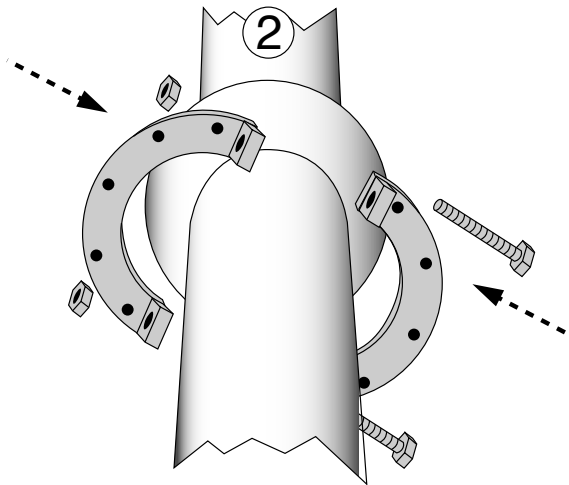

Step 2 • The backing ring of the leak clamp has been packaged as a component set. Do not exchange components of one set with another. Assemble the backing ring and splice plate behind the pipe bell. Center the backing ring behind the bell.

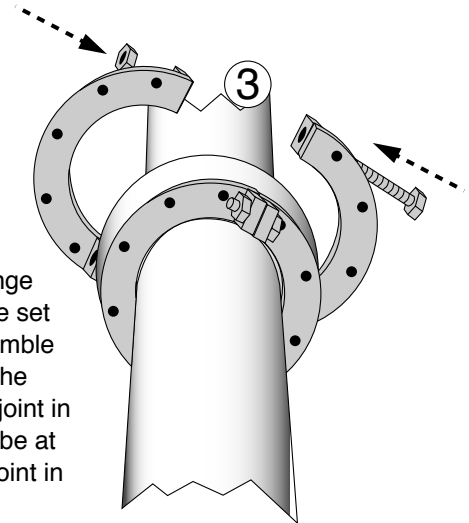
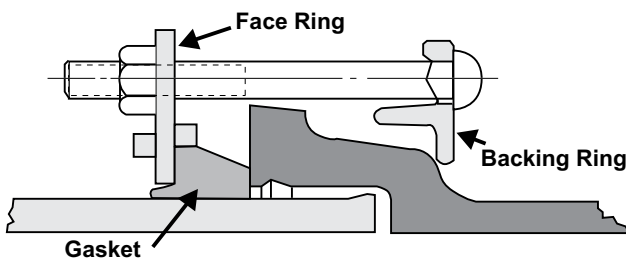

Step 3 • The face ring of the leak clamp has been packaged as a component set. Do not exchange components of one set with another. Assemble the face ring with the splice plates. The joint in the gasket should be at least 9" from any joint in the face ring

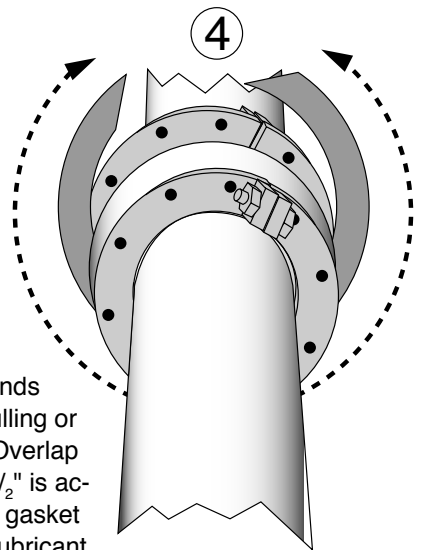

Step 4 • Wrap the gasket around the pipe with the narrow edge toward the bell. Push the gasket into the gasket recess in the face ring. The gasket ends should meet without pulling or stretching the gasket. Overlap of the gasket ends by 1/2" is acceptable. Lubricate the gasket with a suitable gasket lubricant.

Installation Instructions continued on back

Style 416 & 418 Continued from front

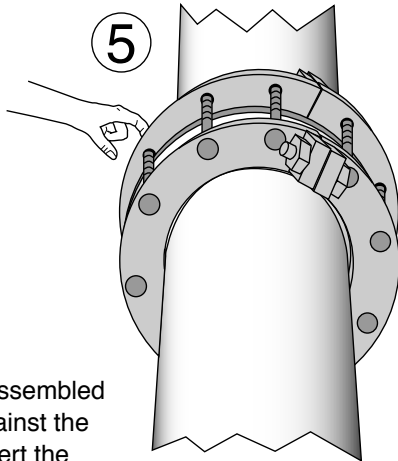

Step 5 • Push the assembled face ring and gasket against the face of the pipe bell. Insert the bolts through the backing ring into the face ring. Hand tighten all the bolts.

Step 6 • Make certain the gasket is in the gasket recess in the face ring.

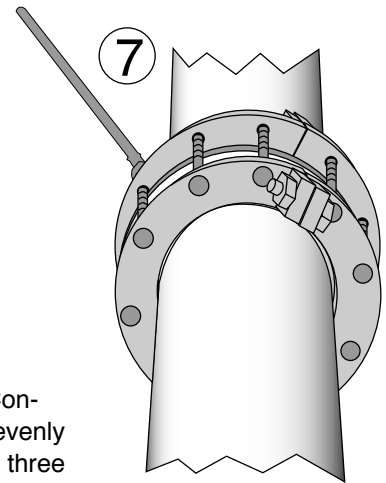

Step 7 • Tighten the bolts evenly to 30 ft-lbs. Continue tightening the bolts evenly to 60 ft-lbs. Tighten two to three times to be certain that the bolts are tightened adequately.

Step 8 • Check for leaking. Re-tighten the bolts evenly around the pipe as necessary to stop leaking.

CAUTION: When reinstalling parts with stainless steel hardware there may be a loss in pressure holding ability due to worn or damaged threads during the original installation.