

INSTALLATION INSTRUCTIONS

Read installation instructions first before installing. Check parts to ensure that no damage has occurred during transit and that no parts are missing. Also check the diameter of the pipe and the size marked on the Harness Lugs to ensure you have the proper size.

Style 490 Harness Lug

Step 1 • Check flange size and class for compatibility with 490 Harness Lug. Compatible flanges are: ANSI B16.1 CLS 125, ANSI B16.5 CLS 150, AWWA C207 CLS B, AWWA C207 CLS D, and AWWA C207 CLS E flanges.



CAUTION: Flanges with hub: The 490 harness lugs are designed with a radius to clear CLS D & CLS E hub flanges as well as most high hub ductile iron threaded flanges. Check to verify lug clearance over flange hub using "ØD" shown in the table below.)

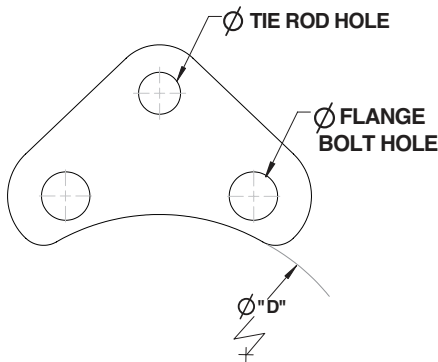

Step 2 • Determine tie rod requirements per the table below. Tie rod quantities listed are for alloy steel (A193 GR B7), 304 SS (A193 GR B7) or 316 SS (A193 GR B8M).

FLANGE SIZE	REQUIRED TIE ROD QUANTITY, MAXIMUM PRESSURE					TIE ROD SIZE (UNC)	LUG THICKNESS	LUG DIAMETER (FOR CLEARANCE) ØD
	50 PSI	100 PSI	150 PSI	200 PSI	275 PSI			
3	2	2	2	2	2	5/8	0.50	Ø4.80
4	2	2	2	2	2	5/8	0.50	Ø6.38
6	2	2	2	2	2	5/8	0.75	Ø8.16
8	2	2	2	3	3	5/8	0.75	Ø10.38
10	2	2	2	3	3	3/4	1.00	Ø12.68
12	2	2	2	3	3	7/8	1.00	Ø15.12
14	2	2	2	3	3	1	1.00	Ø16.68
16	2	2	2	3	4	1	1.00	Ø19.32
18	2	2	3	4	5	1	1.00	Ø20.90
20	2	3	4	5	6	1	1.00	Ø23.00
24	2	3	5	6	9	1	1.00	Ø27.28
30	2	3	5	6	9	1 1/4	1.25	Ø33.82
36	3	5	7	9	12	1 1/4	1.25	Ø40.12
42	3	6	9	12	16	1 1/4	1.25	Ø46.68
48	3	6	8	11	15	1 1/2	1.75	Ø52.82
54	4	7	10	14	18	1 1/2	1.75	Ø59.26
60	5	9	13	17	23	1 1/2	1.75	Ø65.76
66	4	8	11	15	20	1 3/4	2.00	Ø72.00
72	5	9	13	18	24	1 3/4	2.00	Ø79.00

Step 3 • Install harness lugs behind the flanges to be restrained with equal spacing between each lug. If equal spacing is not an option, install harness lugs symmetrically.



CAUTION: Harness Lugs should be installed so that the tie rods are not at an angle.

Use standard hex head flange bolts & nuts (not provided) with a minimum length per the formula shown below. Flange bolts & nuts should be Grade 5 or more. If stainless steel bolts are used, anti-galling lubricant should be applied to the threads.

Minimum harness lug bolt length = (2 x FLG THK) + HARNESS LUG THK + GASKET THK + NUT THK. + 0.13.

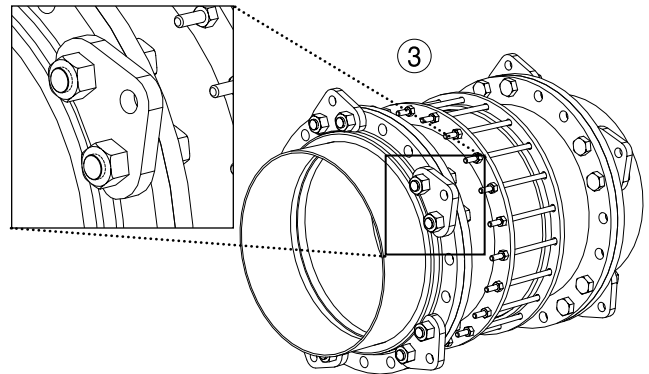

Step 4 • Install remaining flange bolts & nuts. Use standard hex head flange bolts and nuts with a minimum length per the formula shown below. Flange bolts and nuts should be grade 5 or more.

Minimum flange bolt length = 2 x FLG THK + GASKET THK + NUT THK. + 0.13

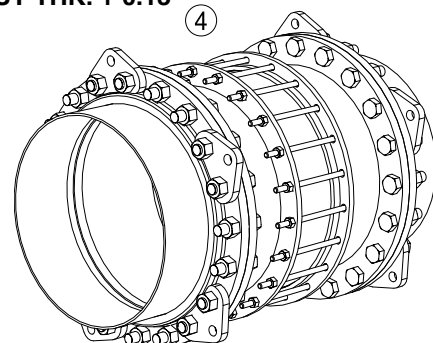

Style 490 Harness Lug

Step 5 • Evenly tighten the bolts around the flange by diametrically alternating opposite positions at approximately 25 ft-lb increments until the recommended torque shown in the table below is achieved.

Wait ten minutes and then re-torque.

BOLT TORQUE RECOMMENDATION		
Flange Size	Bolt Size	Torque (ft-lbs)
4	5/8"	60
6-8	3/4"	100
10-12	7/8"	160
14-16	1 "	245
18-20	1 1/8"	355
24-30	1 1/4"	500
36-48	1 1/2"	875
54-72	1 3/4"	1380

Step 6 • Insert tie rod through top hole of harness lugs. Each harness lug will have 1 nut on each side of the lug (4 nuts per rod). While inserting the tie rod, thread nuts into position. Hand tighten the nuts against harness lug. Make sure the tie rod is centered so that equal amounts stick out from each harness lug end.

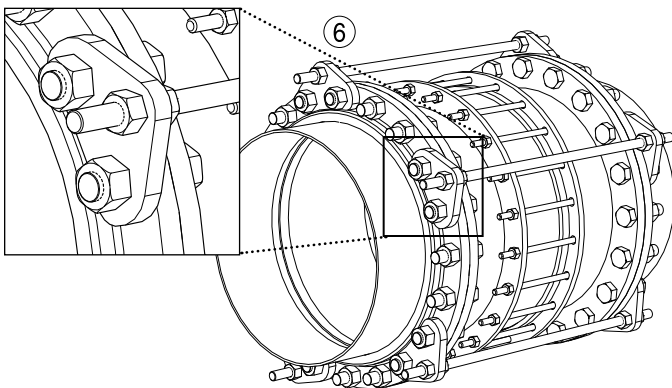

Step 7 • Torque nuts on each side of harness lug simultaneously to the recommended torque shown in the Bolt Torque table (Step 5) to apply a "clamping" load to the harness lug (see illustration below). Do not tighten down tie rod nuts independently as this will induce a bending load on the harness lug and may cause it to fail under load. A thread locking gel (such as Loctite) may be used to ensure the nuts will stay in place.

