

# INSTALLATION INSTRUCTIONS

Read installation instructions first before installing. Check parts to ensure that no damage has occurred during transit and that no parts are missing. Also check the diameter of the pipe and the range marked on the restrainer to ensure you have the proper size.

## 4" - 12" 611 Restrainer for Bell Joints and Romac 501 & 511 Couplings

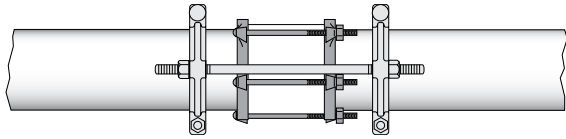

**NOTE: Not for use on polyethylene pipe, plain end mechanical joint fittings or steel pipe.**

**Step 1** • Assemble the bell joint or coupling per manufacturer's installation instructions.

**Step 2** • Clean pipe surface on both sides of the bell joint/coupling to remove as much dirt, coating, and corrosion as possible. Check diameter of pipe to make sure you are using the correctly sized restrainer.

**Note:** Use BLACK restrainer on ductile iron and C900 pipe. Use RED restrainer on IPS size PVC pipe.

**Step 3** • Place one set of restrainer castings on each side of the bell joint/coupling. Loosely install clamping bolts. Restrainers should be equally spaced on each side of the joint. Use the following chart to determine spacing:

Nom. Size	Number of Restraining Rods	Restraining Rod Length	Suggested Distance between Restrainers
4"	2	18"	12"
6"	2	20"	12"
8"	2	20"	12"
10"	4	22"	14"
12"	4	22"	14"

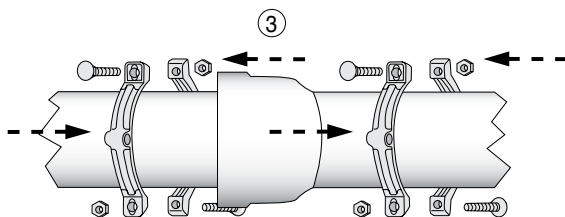

### Step 4 •

Rotate one of the restrainer assemblies so that the loops are aligned with the loops in the opposing restrainer. Slide the restraining rods through the loops and install a nut on each rod end. Make sure the nut is fully engaged on the rod.

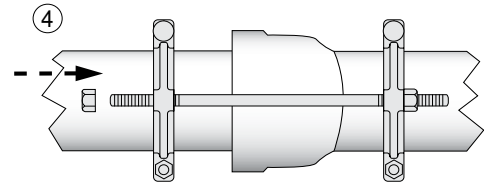

**Note:** When used with couplings the restrainers may need to be rotated so the rods clear the coupling bolts.

**Step 5** • Make sure both restrainer assemblies are perpendicular to the pipe and the restraining rods are parallel to the pipe.

Tighten the clamping bolts to the proper torque per the chart below.

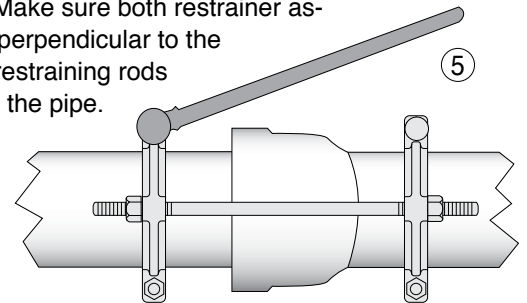

Nom. Pipe Diameter	Bolt Size	Torque
4" & 6"	5/8"	90 ft-lbs
8"	3/4"	150 ft-lbs.
10" & 12"	7/8"	190 ft-lbs.

**Note:** The clamping bolts should be tightened in a manner that keeps the gaps between the castings equal on both sides.

**Step 6** • Tighten all nuts on the restraining rods hand tight.

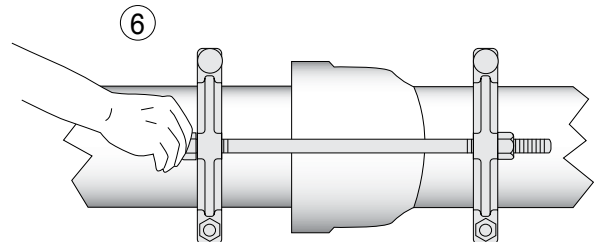

## 4" - 12" 611 Restrainer for Bell Joints and Romac 501 & 511 Couplings

### PRECAUTIONS

1. Check diameter of pipe to make sure you are using the correctly sized restrainer. Black is for ductile iron and C900 pipe, Red is for IPS PVC.

NOMINAL PIPE O.D.		
Size	D.I. Size (C-900)	IPS Size
4"	4.80	4.50
6"	6.90	6.63
8"	9.05	8.63
10"	11.10	10.75
12"	13.20	12.75

2. Clean pipe to remove as much dirt, coatings, and corrosion as possible from the surface.
3. Make sure no foreign materials become lodged between the restrainer halves or between the restrainer and pipe.
4. Avoid loose fitting wrenches, or wrenches so short that achieving proper torque is difficult.
5. Keep threads free of foreign material to allow proper tightening.
6. Bolts are often not tightened enough when a torque wrench is not used. Take extra care in this situation to make sure bolts are properly tightened.
7. Over-tightening the restraining rod nuts can dislodge the bell joint (coupling) and draw the pipe ends together. This can put excessive stress on the pipe.
8. Pressure test for leaks before backfilling.
9. Backfill and compact carefully around pipe and fittings.

### COMMON INSTALLATION PROBLEMS

1. Not enough torque on clamping bolts.
2. Debris lodged between restrainer halves or between restrainer and pipe.
3. Dirty threads on bolts or nuts.
4. Not using the proper size restrainer for the pipe.
5. Forgetting to tighten clamping bolts and/or coupling bolts.

### IF RESTRAINER MUST BE REMOVED

1. Make sure pipe is not pressurized. Removing the restrainer could cause the pipe joint to separate.
2. Make sure a restraining system is in place before re-pressurizing pipe.