

# INSTALLATION INSTRUCTIONS

Read installation instructions first before installing. Check parts to ensure that no damage has occurred during transit and that no parts are missing. Also check the diameter of the pipe and the range marked on the restrainer to ensure you have the proper size.

## 4" - 12" 612 Restrainer

### for Mechanical Joints & Push-On Fittings with Restraint Ears

**NOTE: Not for use on polyethylene pipe, plain end mechanical joint fittings or steel pipe.**

**Step 1** • Clean pipe surface to remove as much dirt, coating, and corrosion as possible. Check diameter of pipe to make sure you are using the correctly sized restrainer.

**Note:** Use BLACK restrainer on ductile iron and C900 pipe. Use RED restrainer on IPS PVC size pipe.

**Step 2** • Install the MJ fitting per AWWA C111 on the pipe, leaving out T-bolts that match loops in the restrainer. Tighten T-bolts hand tight.

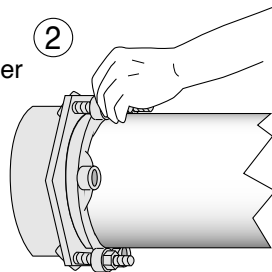

**Step 3** • Install the long restraining T-bolts in the MJ fitting. Install one nut on each T-bolt, snugging it up hand tight against the MJ gland.

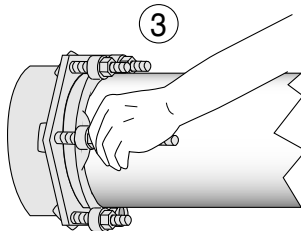

**Note:** 10" and 12" restrainers have four restraining T-bolts.

**Step 4** • Place restrainer castings on the pipe, and loosely install clamping bolts.

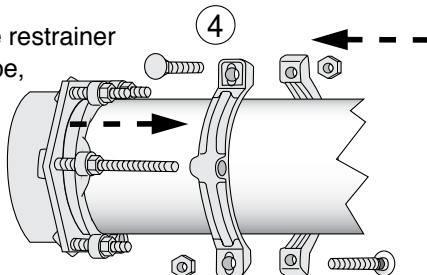

**Step 5** • Rotate the restrainer assembly so that the loops are aligned with the restraining T-bolts. Slide the assembly over the long T-bolts and install a second nut on each long T-bolt.

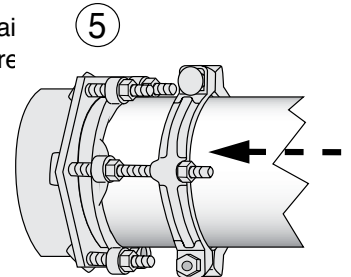

**Step 6** • Make sure the restrainer assembly is perpendicular to the pipe. Tighten the restrainer clamping bolts to the proper torque per the chart below.

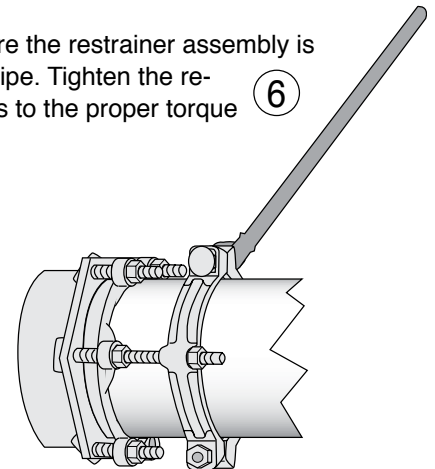

Nom. Pipe Diameter	Bolt Size	Torque
4" & 6"	5/8"	90 ft-lbs.
8"	3/4"	150 ft-lbs.
10" & 12"	7/8"	190 ft-lbs.

**Note:** The clamping bolts should be tightened in a manner that keeps the gaps between the castings equal on both sides.

**Step 7** • Tighten T-bolts on MJ gland to 75 - 90 ft-lbs torque per AWWA C111.

**Step 8** • Re-check nuts coupling the long T-bolt to the restrainer assembly; make sure that each nut is hand tight.

## 4" - 12" 612 Restrainer for Mechanical Joints & Push-On Fittings with Restraint Ears

### PRECAUTIONS

1. Check diameter of pipe to make sure you are using the correctly sized restrainer. Black is for D.I. (C900) size pipe, Red is for IPS.

NOMINAL PIPE O.D.		
Size	D.I. Size (C-900)	IPS Size
4"	4.80	4.50
6"	6.90	6.63
8"	9.05	8.63
10"	11.10	10.75
12"	13.20	12.75

2. Clean pipe to remove as much dirt, coatings, and corrosion as possible from the surface.
3. Make sure no foreign materials become lodged between the restrainer halves or between the restrainer and pipe.
4. Avoid loose fitting wrenches, or wrenches so short that achieving proper torque is difficult.
5. Keep threads free of foreign material to allow proper tightening.
6. Bolts are often not tightened enough when a torque wrench is not used. Take extra care in this situation to make sure bolts are properly tightened.
7. Over-tightening the restraining rod nuts can dislodge the mechanical joint fitting and bottom out the pipe in the fitting. This can put excessive stress on the system.
8. Pressure test for leaks before backfilling.
9. Backfill and compact carefully around pipe and fittings.
10. When reinstalling parts with stainless steel hardware there may be a loss in pressure holding ability due to worn or damaged threads during the original installation

### COMMON INSTALLATION ERRORS

1. Not enough torque on clamping bolts.
2. Debris lodged between restrainer halves or between restrainer and pipe.
3. Dirty threads on bolts or nuts.
4. Not using the proper size restrainer for the pipe.
5. Forgetting to tighten clamping bolts and/or coupling bolts.

### IF RESTRAINER MUST BE REMOVED

1. Make sure pipe is not pressurized. Removing the restrainer could cause the pipe joint to separate.
2. Make sure a restraining system is in place before re-pressurizing pipe.