

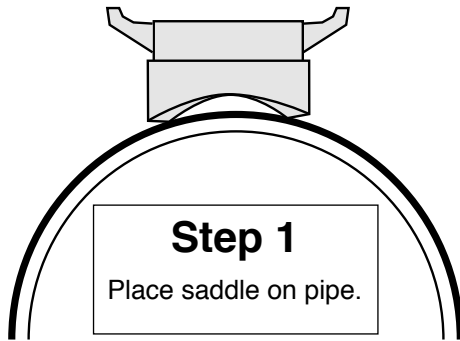

INSTALLATION INSTRUCTIONS

Read installation instructions first before installing. Check parts to ensure that no damage has occurred during transit and that no parts are missing. Also check the diameter of the pipe and the range marked on the saddle to ensure you have the proper size.

Style "CB" Sewer Saddle



Step 1
Place saddle on pipe.

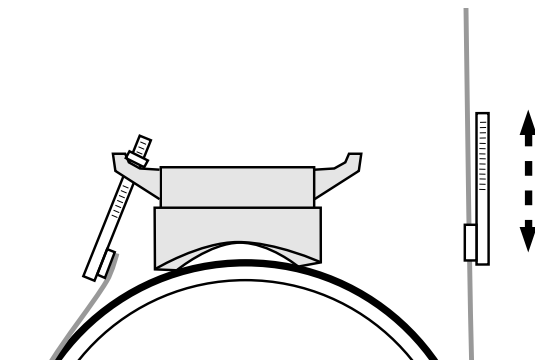

Step 2
Wrap strap around pipe, with "This Side Out" as printed on strap. Slide the adjustable bolt assembly to a point which leaves most of the thread for tightening.

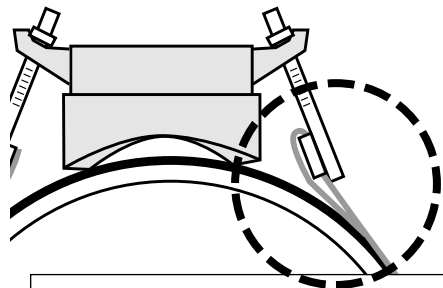

Step 3
Fold strap back against itself, placing free end between strap and pipe. (On small pipe, it may be necessary to fold loose end twice).

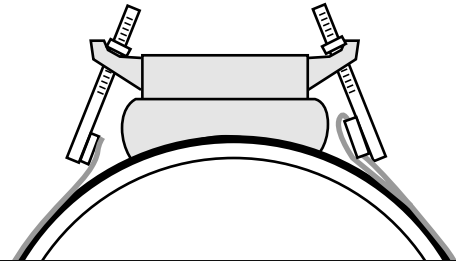

Step 4
Tighten nuts evenly, alternating between them until appropriate torque is reached (see below).
Significant flattening of PVC pipe indicates over-tightening. In all cases wait 10 minutes and retorque.

Nom. Pipe Diameter	Torque
6" - 12"	15-20 ft-lbs.
14" - 48"	20-30 ft-lbs.

Note
25 ft-lbs. = 12" wrench w/25 lbs. force

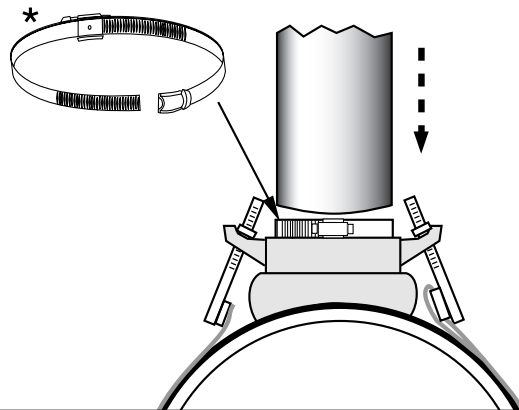

Step 5
Lubricate and insert branch end.

*The CB UN saddles are provided with a band clamp (hose clamp) which allows it to have a range. The band clamp comes with two adjusting screws which provide much greater clamping force than band clamps with only one adjusting screw. The band clamp needs to be assembled around the outlet and both adjusting screws tightened evenly.

Style “CB” Sewer Saddle

PRECAUTIONS

1. Check diameter of main and branch pipe to make sure you are using the correct size saddle gasket; also check gasket to make sure it is the size you think it is.
2. Remove as much dirt and corrosion from pipe surfaces as possible.
3. Make sure no foreign materials lodge between saddle gasket and pipe as nuts are tightened.
4. Avoid loose fitting wrenches or wrenches too short to achieve proper torque.
5. Take extra care to follow proper bolt tightening procedures and torque recommendations: 15-20 ft-lbs. for 6" - 12" mains and 20-30 ft-lbs. for 14" - 48" mains (wait 10 minutes and retorque).
6. Backfill and compact carefully around branch.
7. The hole cut in the main should be no larger than the inside diameter of the saddle gasket. The 4" gasket has an I.D. of 5.20, the six inch gasket has an I.D. of 6.40.
8. Lubricating between the saddle gasket and the main on rough or large O.D. pipe can improve the sealing capacity of the saddle.
10. During installation the temperature of the saddle gasket itself can be important. The temperature of the saddle gasket should not fall below ~ 45° F.
11. It is necessary to bevel the branch pipe end and lubricate pipe end and saddle gasket hub.
12. When reinstalling parts with stainless steel hardware there may be a loss in pressure holding ability due to worn or damaged threads during the original installation

COMMON INSTALLATION PROBLEMS

1. Bolts are not tightened to the proper torque.
2. Rocks or debris cutting gasket.
3. Dirt on threads of bolts or nuts.
4. Strap is installed improperly.
5. Using excessive force to insert branch pipe (do not use a backhoe, hydraulic jack or similar mechanical devices to insert branch pipe).
6. Inserting pipe with jagged ends or pipe with uneven cut ends into saddle gasket
7. Not using band clamp on CB UN saddles.