

# INSTALLATION INSTRUCTIONS

Read installation instructions first before installing. Check parts to ensure that no damage has occurred during transit and that no parts are missing. Also check the diameter of the pipe and the size marked on the Dismantling Joint to ensure you have the proper size.

## Style DJ400 14"-72" Dismantling Joints

**Step 1** Check the DJ400 parts to ensure no damage occurred during transit and that no parts are missing.

**Step 2** Check the mating flanges to insure that it matches the drilling of the DJ400. They must be parallel and aligned axially.

**Step 3** Remove the tie-rods from the DJ400 and loosen the end ring bolts to allow the spool piece to move freely within the Flange Coupling body.

**Step 4** Move the DJ400 into position between the mating flanges. Insert the flange gasket between the flange faces (not provided). Using flange bolts, fasten the flanged coupling end of the dismantling joint to one of the mating flanges. Depending on the situation, the tie-rods might need to be inserted concurrently with the flange bolts.

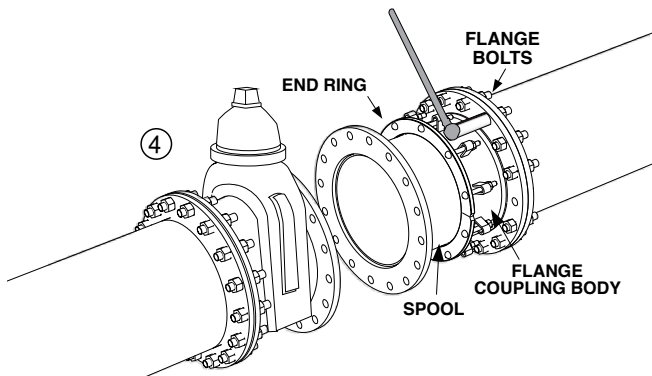

**Step 5** Attach the flanged spool to the opposite mating flange in your system and fasten together with flange bolts. Make sure the spool piece is inserted at least 2 inches inside of the Flange Coupling body.

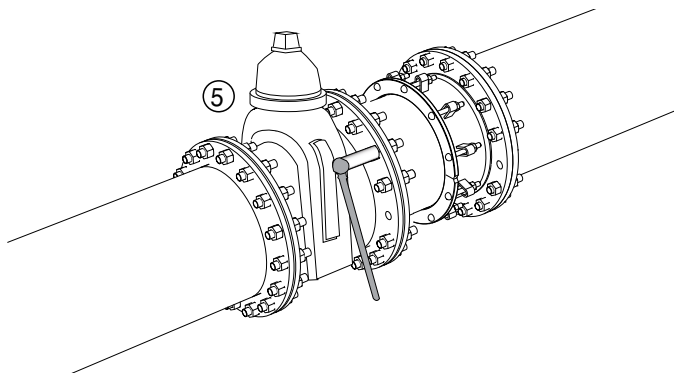

**Step 6** The pipe spool piece should be concentric with the flanged coupling after bolting the flanges. If the flanged coupling was completely disassembled, make sure the beveled edge of the gasket matches the beveled end of the flanged coupling. Slide end ring into position and hand tighten the end ring bolts.

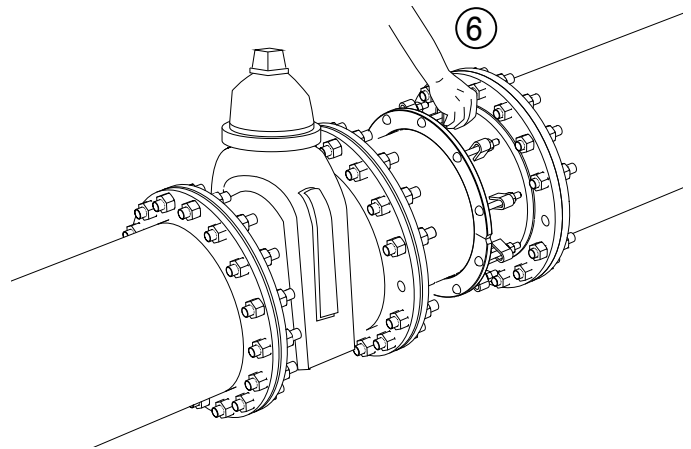

**Step 7** Insert tie-rods. (NOTE: Without the tie-rods in place, the fitting is NOT RESTRAINED.) Each tie-rod will have a total of 4 nuts when assembled. While inserting the tie-rod, thread the nuts into position. The tie-rod must pass through the flanges on each end of the dismantling joint. Make sure the tie-rod lengths are equal. Tighten the nuts that secure the flanges BEFORE torquing the nuts on the end ring to complete the installation.

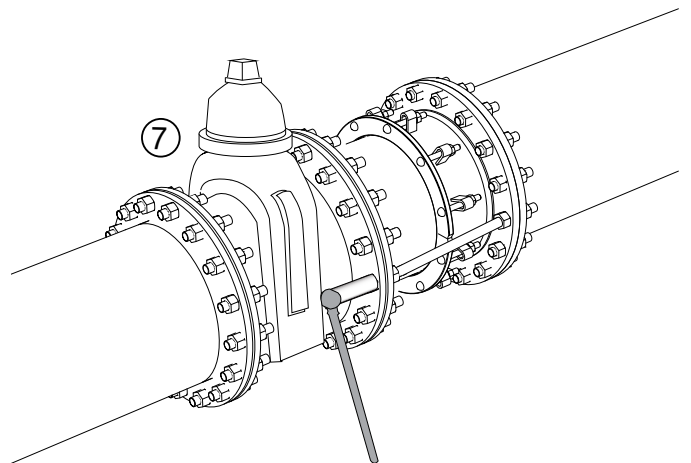

## Style DJ400 14-72" Dismantling Joints (continued from front)

**Step 8** Evenly tighten the bolts around the end ring by diametrically alternating opposite positions at approximately 25 ft-lb increments until the recommended torque is achieved. Wait ten minutes and then retorque.

Recommended torque for end rings is 60-70 ft-lbs.

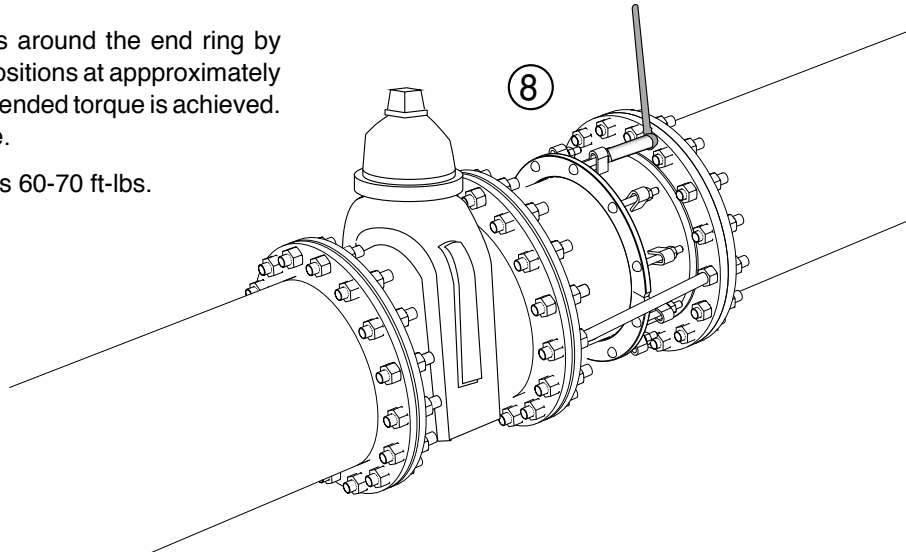

### PRECAUTIONS

1. Check flanges to make sure you are using the correct size DJ400; also check the length of DJ400 to make sure it will fit in the space allocated.
2. Make sure no foreign materials lodge between gasket and spool.
3. Avoid loose fitting wrenches, or wrenches too short to achieve proper torque.
4. Keep threads free of foreign material to allow proper tightening.
5. Take extra care to follow proper bolt tightening procedures and torque recommendations. Bolts are often not tightened enough when a torque wrench is not used.
6. Pressure test for leaks before backfilling.
7. Backfill and compact carefully around pipe and fittings.
8. When reinstalling parts with stainless steel hardware, there may be a loss in pressure holding ability due to worn or damaged threads during the original installation.

### COMMON INSTALLATION PROBLEMS

1. Bolts are not tightened to the proper torque.
2. Rocks or debris between spool and gasket.
3. Dirt on threads of bolts or nuts.
4. Not enough pipe insertion.
5. Incorrect mating flange.