

# INSTALLATION INSTRUCTIONS

Read installation instructions first before installing. Check parts to ensure that no damage has occurred during transit and that no parts are missing. Also check the diameter of the pipe and the range marked on the coupling to ensure you have the proper size.

## Style EC501 Coupling

**Step 1** • Check the coupling parts to insure that no damage has occurred during transit and that no parts are missing.

**Step 2** • Clean pipe end for a distance of 2" greater than length of the coupling.

**Step 3** • Check area where gasket will seat on the pipe to make sure there are no dents, projections, gouges, etc., that will interfere with the gasket seal. Welds must be ground flush.

**Step 4** • Place reference mark on the pipe, use the reference mark to insure a minimum of 3" inches of pipe insertion into the center ring.

**Step 5** • Place an end ring on pipe end.

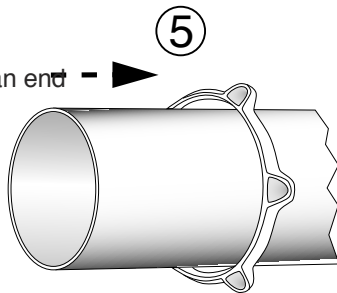

**Step 6** • Lubricate the gaskets and pipe surface with a suitable gasket lubricant.

**Step 7** • Place a gasket next to end ring, with beveled edge toward the pipe end.

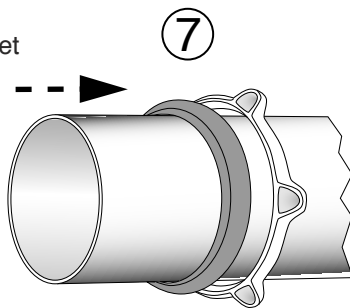

**Step 8** • Slide center ring on pipe end. The center ring should be centered such that the space between the OD of the pipe and the ID of the center ring is even all around the pipe.

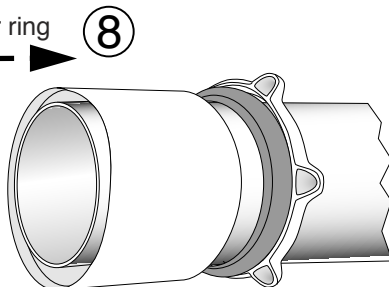

**Step 9** • Slide gasket into position with the beveled edge engaging the flared end of the center ring. Slide the end ring into position against the gasket.

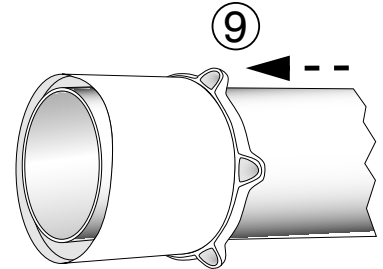

**Step 10** • Install the end ring/end cap assembly. 4" through 8" sizes have two separate pieces, the end ring and the end cap. 10" and 12" sizes are one piece. Place gasket in the end cap.

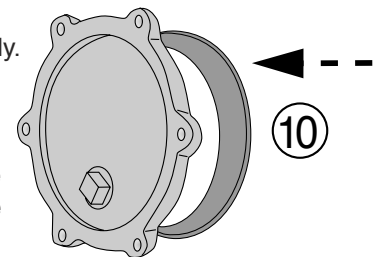

**Step 11** • Slide end cap assembly into center ring, with beveled edge of gasket facing toward center ring. Check coupling for proper positioning over pipe ends using reference marks. (See Step 4)

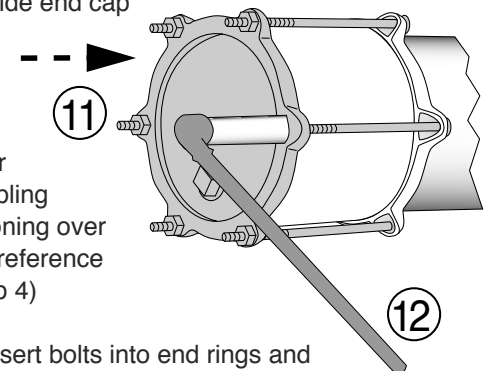

**Step 12** • Insert bolts into end rings and tighten. Bolt tightening should be done evenly, alternating to diametrically opposite positions at approximately 20 ft-lbs. increments to bring bolts to recommended tightness.

Nom. Pipe Diameter	Torque
4" - 12"	40-50 ft-lbs.
16"	60-70 ft-lbs.

**Note:**  
50 ft-lbs. torque = 12" wrench w/50 lbs. force  
70 ft-lbs. torque = 12" wrench w/70 lbs. force

**Step 13** • After pipe is pressurized, check for leakage and tighten as necessary.

**Note: Flexible Couplings do not provide protection against possible pullout of pipe ends in unrestrained conditions.**

## Style EC501 Coupling

### PRECAUTIONS

1. Check diameter of pipe to make sure you are using the correct size coupling; also check gasket to make sure it is the size you think it is.
2. Clean pipe to remove dirt and corrosion from pipe surface. Lubrication and additional cleaning should be provided by brushing both the gasket and plain pipe end with soapy water or approved pipe lubricant per ANSI/AWWA C111/A21.11.
3. Make sure no foreign materials lodge between gasket and pipe.
4. Avoid loose fitting wrenches, or wrenches too short to achieve proper torque.
5. Keep threads free of foreign material to allow proper tightening.
6. Take extra care to follow proper bolt tightening procedures and torque recommendations. Bolts are often not tightened enough when a torque wrench is not used.
7. Pressure test for leaks before backfilling.
8. Backfill and compact carefully around pipe and fittings.
9. When reinstalling parts with stainless steel hardware there may be a loss in pressure holding ability due to worn or damaged threads during the original installation.

### COMMON INSTALLATION PROBLEMS

1. Bolts are not tightened to the proper torque.
2. Rocks or debris between pipe and gasket.
3. Dirt on threads of bolts or nuts.
4. Pipe not inserted into the coupling far enough.
5. Center ring not centered evenly around pipe.
6. Too much pipe deflection.