

# INSTALLATION INSTRUCTIONS

Read installation instructions first before installing. Check parts to ensure that no damage has occurred during transit and that no parts are missing. Also check the diameter of the pipe and the range marked on the coupling to ensure you have the proper size.

## Style ECF400 (3"-12")

### Equipment Connection Fitting - Restraint for misaligned flanged fittings

#### Parts List

- (2) Flanged Coupling Adapter; includes body, end ring, gasket, thru-bolts and nuts
- (1) Pipe Spool; plain ends
- Harness Lugs; quantity depends on size and pressure {see Drawings for details}
- Tie Rods; all thread rod per ASTM A193, quantity depends on size and pressure, 2 heavy hex nuts per rod {see Drawings for details}
- Spherical Washers; quantity depends on size and pressure {see Drawings for details}

**Step 1** • Inspect the ECF400 to ensure that no damage occurred during transit and no parts are missing.

**Step 2** • Check the mating flanges to insure that they match the flange drilling of the ECF400. Also, confirm that the flange misalignment or offset is within the tolerance that the ECF400 will accommodate. (Refer to the appropriate dimensional drawing. Go to [www.romacindustries.com](http://www.romacindustries.com))

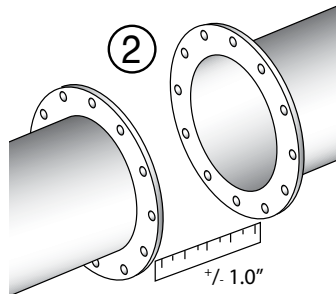

**Step 3** • Unpack the fitting. Loosen the end ring nuts on the thru-bolts to allow the spool piece to move freely within the flange coupling bodies. Remove the nuts that are on the flange face (O-Ring gasket seal is on this side). Place a mark at the center of the spool piece to make it easier to center the spool during assembly.

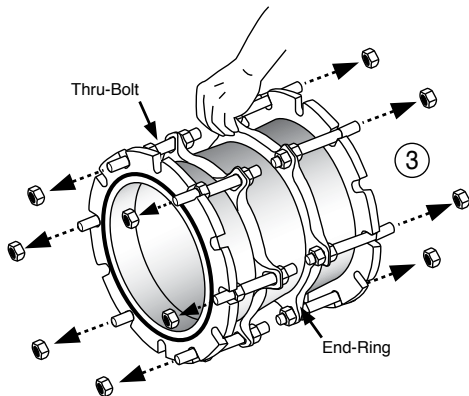

**Step 4** • Lift the ECF400 into position with the flanged coupling assemblies intact and fit the protruding thru-bolts into the corresponding flange bolt holes. On each flanged end, thread the nuts back on the thru-bolts and tighten securely.

For 3" – 10" ECF400 sizes, tighten to 50 ft-lbs. For 12" ECF400 size, tighten to 90 ft-lbs.

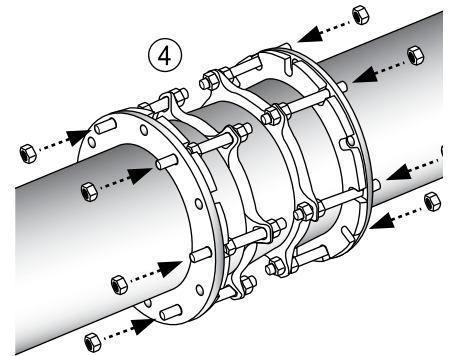

**Step 5** • Once both flange joints are assembled and properly tightened, make sure the pipe spool is centered between the flanged coupling bodies. The end ring and gaskets should already be loosely assembled, but if they are not, slide the flange coupling gasket into position with the beveled edge engaging the beveled end of the flange coupling body and slide the end ring (engaging the bolts) against the gasket.

**Step 6** • Tighten the end ring bolts evenly by alternating to diametrically opposite positions at 20 ft-lb increments. Once the recommend torque is achieved, wait ten minutes and retighten.

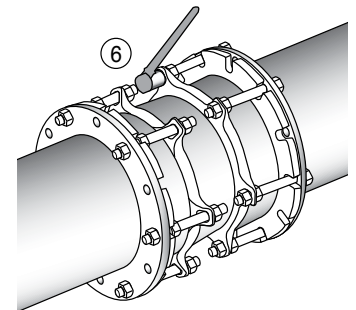

#### RECOMMENDED TORQUE

Bolt Size	End Ring Bolts	Flange Bolts
5/8"	60 - 70 ft-lbs.	75 - 85 ft-lbs.
3/4"	75 - 85 ft-lbs.	90 - 100 ft-lbs.
7/8"	85 - 95 ft-lbs.	150 - 160 ft-lbs.

Installation Instructions continued on back

# INSTALLATION INSTRUCTIONS

## Style ECF400 (3"-12")

### Equipment Connection Fitting - Restraint for misaligned flanged fittings

**Step 7 • Harness Assembly.** Attach a harness lug to the back of a mating flange with flange bolt and nut. The rounded edge of the harness lug should be facing outward. On the opposite corresponding mating flange hole, attach another lug. Repeat this process so the lugs are symmetric around the ECF400.

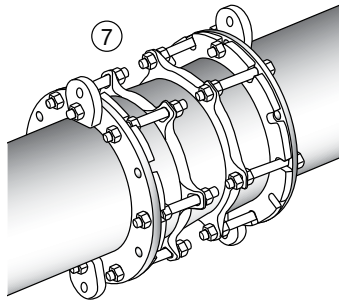

**Step 8 •** Install the tie rod through the harness lugs and place a set of spherical washers on the back side of each harness lug. Attach a nut at each end and tighten finger tight and then another  $\frac{1}{2}$  turn.

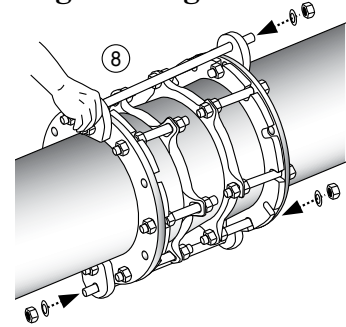

Do not over tighten.

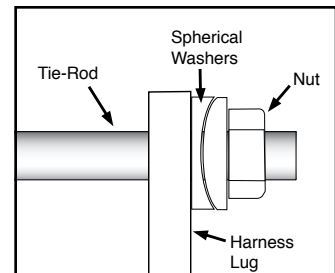

## PRECAUTIONS

1. Check flanges to make sure you are using the correct size ECF400; also check the length of ECF400 to make sure it will fit in the space allocated.
2. Make sure no foreign materials lodge between gasket and spool.
3. Avoid loose fitting wrenches, or wrenches too short to achieve proper torque.
4. Keep threads free of foreign material to allow proper tightening.
5. Take extra care to follow proper bolt tightening procedures and torque recommendations. Bolts are often not tightened enough when a torque wrench is not used.
6. Pressure test for leaks before backfilling.
7. Backfill and compact carefully around pipe and fittings.
8. When reinstalling parts with stainless steel hardware, there may be a loss in pressure holding ability due to worn or damaged threads during the original installation.

## COMMON INSTALLATION PROBLEMS

1. Bolts are not tightened to the proper torque.
2. Rocks or debris between spool and gasket.
3. Dirt on threads of bolts or nuts.
4. Not enough pipe insertion.
5. Incorrect mating flange.
6. Not having spool piece centered.
7. Over-tightened rod nuts.