

INSTALLATION INSTRUCTIONS

Read installation instructions first before installing. Check parts to ensure that no damage has occurred during transit and that no parts are missing. Also check the diameter of the pipe and the range marked on the coupling to ensure you have the proper size.

Style FC400 Steel Flanged Coupling

Step 1 • Check the flanged coupling parts to insure that no damage has occurred during transit and that no parts are missing.

Step 2 • Clean pipe end for a distance of 2" greater than the length of the flanged coupling.

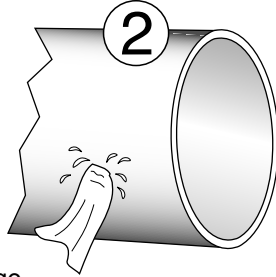

Step 3 • Check area where gaskets will seat on pipe and flange faces to make sure there are no dents, projections, gouges, etc. that will interfere with the gasket seals. Welds must be ground flush.

Step 4 • Place end ring on pipe end.

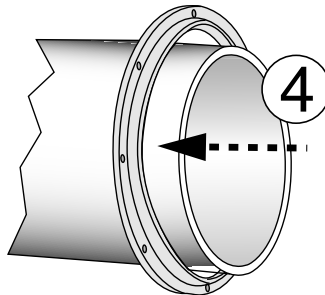

Step 5 • Clean the gasket. Lubricate the gasket and pipe surface with a suitable gasket lubricant. Place gasket next to end ring with beveled edge toward the pipe end.

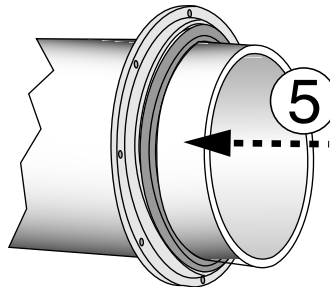

If using Anchor Pins, remove the anchor pins from the half couplings on the flanged coupling body.

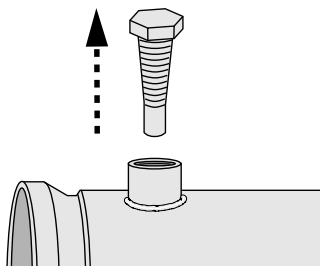

Step 6 • Slide the flanged coupling body onto the pipe end.

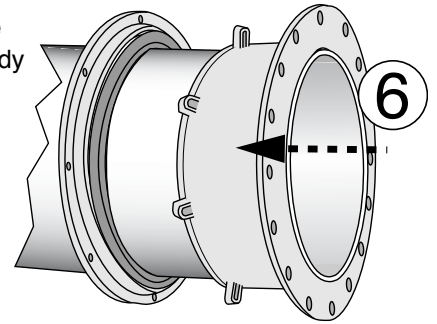

Step 7 • Using a flange gasket, position the flanged coupling against the mating flange, making sure there is a minimum 3 1/2" of pipe insertion. If using Anchor Pins, the minimum pipe insertion is 4 1/2".

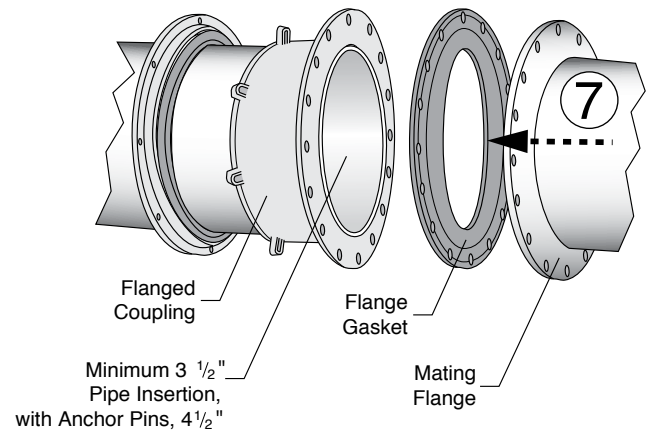

Step 8 • Assemble the flanged joint using flange bolts.

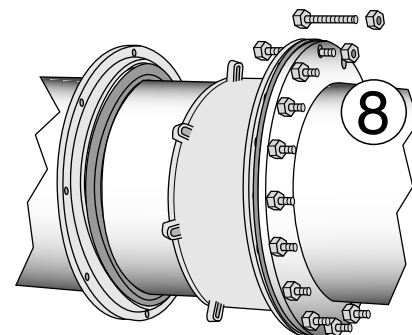

Installation Instructions continued on back

Style FC400 (continued from front)

IF USING ANCHOR PINS

1. Remove Anchor Pins from flanged coupling body.
2. Slide the flanged coupling body onto the pipe end.
3. Position the flanged coupling against the mating flange. Assemble the flanged joint.
4. Thread a short pipe nipple into the threaded Anchor Pin hole. Using the largest drill bit that will fit into the pipe nipple, drill a center mark on the pipe. Do not drill through. Remove the pipe nipple.
5. Use a $\frac{5}{16}$ " diameter drill to drill through the center mark made in step 4.
6. Complete the hole by drilling through the pipe with drill size per the table below.
7. Install the Anchor Pins. Apply a suitable thread sealant and tighten to prevent leakage.

Pin Size	Thread Size	Drill Size for Pipe	Torque (ft-lbs.)
$\frac{7}{8}$ "	$\frac{3}{4}$ " NPT	$\frac{29}{32}$ "	80
1"	1" NPT	$1 \frac{1}{32}$ "	100

Step 9 • Slide the ring gasket into position with the beveled edge engaging the flared end of the flanged coupling body.

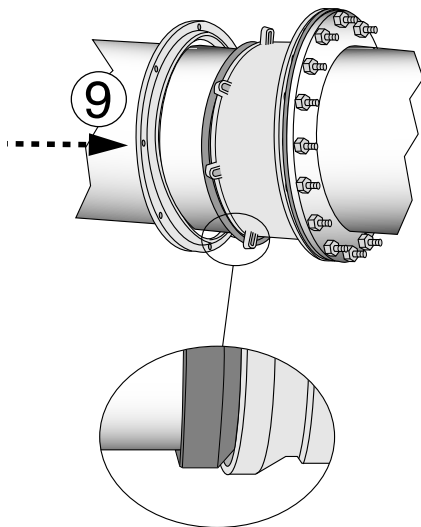

Make sure the beveled edge of the gasket engages the flared end of the flanged coupling body.

Step 10 • Slide the end ring into position against the gasket. Be sure to match weld in end ring with weld in body.

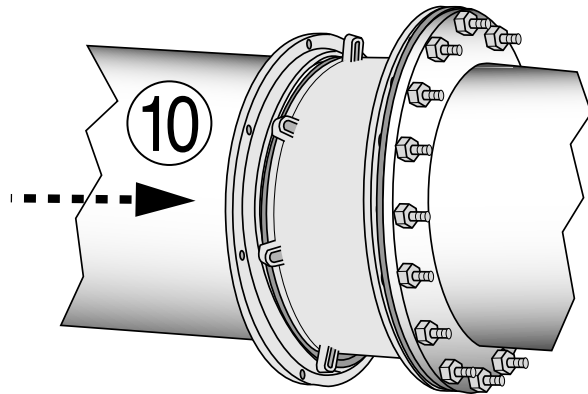

Step 11 • Insert the bolts through the end ring into the anchor loops and tighten. Bolt tightening should be done evenly, alternating to diametrically opposite positions to bring bolts to recommended tightness. (60-70 ft-lbs. for $\frac{5}{8}$ " bolts and 85-95 ft-lbs. for $\frac{3}{4}$ " bolts.)

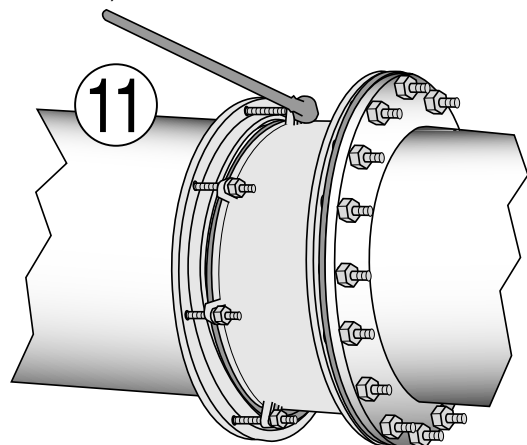

For best results, after pipe is pressurized check for leakage and re-torque as necessary.