



INSTALLATION INSTRUCTIONS

Read installation instructions first before installing. Check parts to ensure that no damage has occurred during transit and that no parts are missing. Also check the diameter of the pipe and the size marked on the coupling to ensure you have the proper size.

FC400RG Restrained Flanged Coupling 12" - 48" with RomaGrip™

NOTE: Not for use on polyethylene pipe, plain end mechanical joint fittings, PVC or HDPE pipe. May be used on cast iron pipe, as long it's the same OD as ductile iron pipe.

Step 1 • Check the FC400RG parts to insure that no damage has occurred during transit and that no parts are missing.

Step 2 • Clean pipe end for a distance of 2" greater than length of the RFCA.

Step 3 • Place RomaGrip gland on pipe end.

Step 4 • Lubricate the gasket and pipe surface with soapy water or other suitable gasket lubricant. Place gasket over pipe with beveled edge toward the flange adapter.

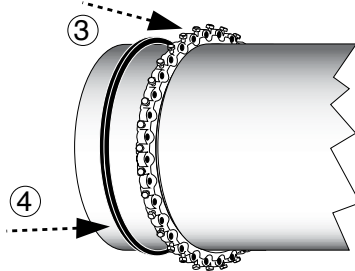

Step 5 • Slide the FC400RG on to the pipe. Position the pipe and flanged coupling against the mating flange, inserting flange gasket between the flange faces. Assemble the flange joint using flange bolts.

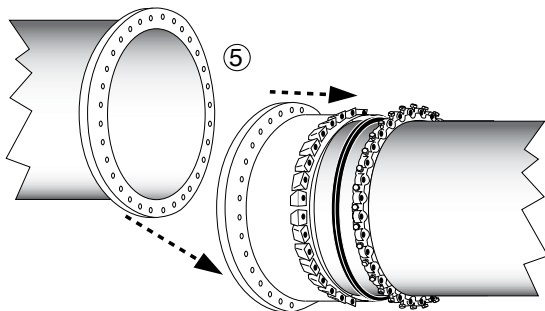

Step 6 • The pipe should be centered such that the space between the OD of the pipe and the ID of the FC400RG is even all around the pipe. Slide the FC400RG gasket into position with the beveled edge engaging the beveled end of the FC400RG body.

Step 7 • Slide the RomaGrip into position against the gasket, and insert the all-thread-rod.

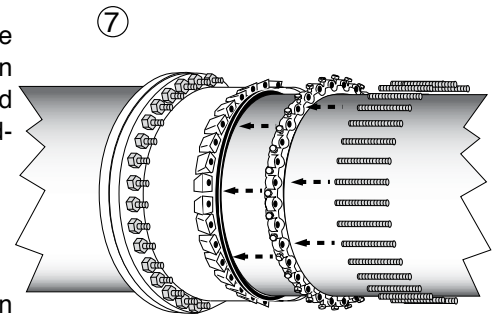

Step 8 • Tighten nuts on all-thread-rod evenly, alternating to diametrically opposite position at approximately 20 ft-lbs increments to the recommended torque for your size FC400RG. Two wrenches will be required.

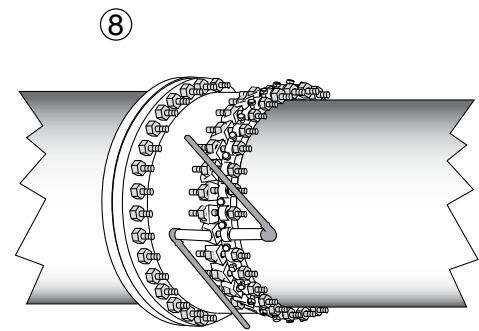

Recommended Torque:

- 12" - 24" RomaGrip - 75 - 90 ft-lbs.
- 30" - 36" RomaGrip - 100 - 120 ft-lbs.
- 42" & 48" RomaGrip - 120 - 150 ft-lbs.

Note:

90 ft-lbs. torque = 12" wrench w/90 lbs. force

For best results, wait 10 minutes and retighten bolts to proper torque.

Step 9 • Tighten the restrainer bolts until the restraining pads touch the surface of the pipe. The bolts should be tightened in a uniform criss-cross pattern, until the heads break off above the notch.

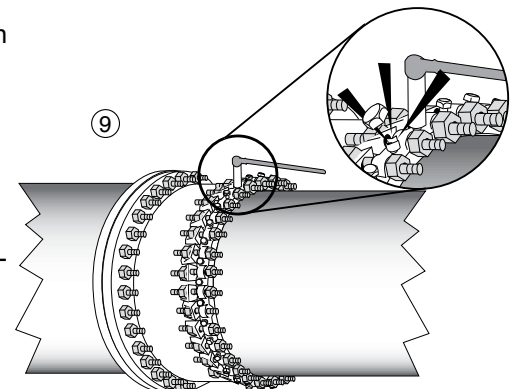

Step 10 • Pressure test for leaks before backfilling.



INSTALLATION INSTRUCTIONS

Style FC400RG Restrained Flanged Coupling with RomaGrip™

NOTE: Not for use on polyethylene pipe, plain end mechanical joint fittings, PVC or HDPE pipe. May be used on cast iron pipe, as long it's the same OD as ductile iron pipe.

PRECAUTIONS

1. Check flange to make sure the bolt holes match the FC400RG.
3. Make sure a flange gasket is used between the mating flanges.
3. Check diameter of pipe to make sure you are using the correct size FC400RG; also check gasket to make sure it is the size required.
4. Be sure to clean pipe of as much dirt and corrosion as possible in the area that the gasket will seal.
5. Lubricate both the gasket and the pipe end with soapy water or approved pipe lubricant per ANSI/AWWA C111/A21.11.
6. Make sure no foreign materials lodge between gasket and pipe.
7. Avoid loose fitting wrenches, or wrenches too short to achieve proper torque.
8. Keep threads free of foreign material to allow proper tightening.
9. Take extra care to follow proper bolt tightening procedures and torque recommendations. Bolts are often not tightened enough when a torque wrench is not used.
10. Be sure that the gland is centered around the pipe.
11. Pressure test for leaks before backfilling.
12. Backfill and compact carefully around pipe and fittings.
13. Some initial axial movement may occur in lug style restraints as the lugs seat. Movement is directly related to the size of the piping system and the system pressure. In general terms movement of approximately 0.25" can be expected in restraints under 16". For larger sizes, movement of approximately 0.4" may be seen. If this is critical to your application please contact Romac Engineering for additional information.

COMMON INSTALLATION PROBLEMS

1. Flange gasket not installed.
2. Bolts are not tightened to the proper torque.
3. Rocks or debris between pipe and gasket.
4. Dirt or debris between pipe and restraining pad.
5. Dirt on threads of bolts or nuts.
6. Restraining bolt heads not snapped off.
7. Not enough pipe inserted into bell.

IF FC400RG MUST BE REMOVED

1. Make sure pipe is not pressurized. Removing the restrainer could cause the pipe joint to separate.
2. To remove the RomaGrip, use a $\frac{5}{8}$ " hex wrench or socket to loosen the restraining bolts.
3. To reassemble, follow installation procedures.
For sizes 12" - 24", tighten the restraining bolts using a $\frac{5}{8}$ " hex wrench to 75-ft-lbs.
For sizes 30" - 48", tighten the restraining bolts using a $\frac{15}{16}$ " hex wrench to 110 - 135 ft-lbs.