



INSTALLATION INSTRUCTIONS

Read installation instructions first before installing. Check parts to ensure that no damage has occurred during transit and that no parts are missing. Also check the diameter of the pipe and the range marked on the tapping sleeve to ensure you have the proper size.

FTS 425 Mechanical Joint Tapping Sleeve

Step 1 • Clean pipe surface in order for gaskets to effect a water tight seal. Clean the pipe for a distance two inches longer than the tapping sleeve.

Step 2 • Note and reference mark the position of the sleeve components. The components **MUST** be assembled on the pipe in the same relative position as shipped from the factory.

Step 3 • Assemble sleeve halves onto pipe: be certain that the side gaskets have not been damaged during shipment and that they are in place. Do not trim side gaskets, side gasket should overlap as shown in detail.

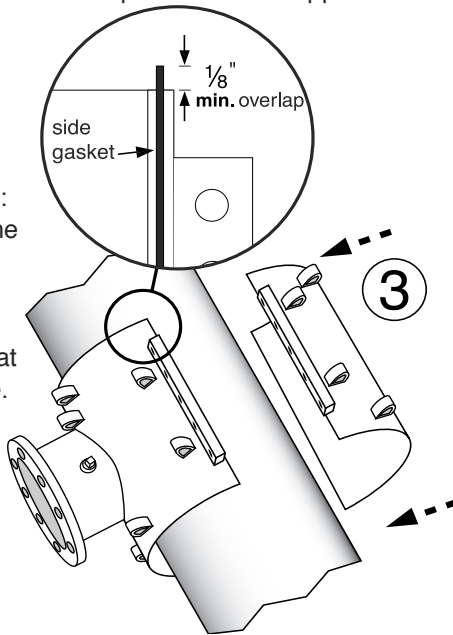

Step 4 • Install and tighten the side bolts evenly to the torque recommended for their diameter:

Bolt Size	Torque (ft-lbs.)
5/8"	70
3/4"	80
7/8"	90
1"	100
Up to 1 1/2"	150
Up to 2"	200

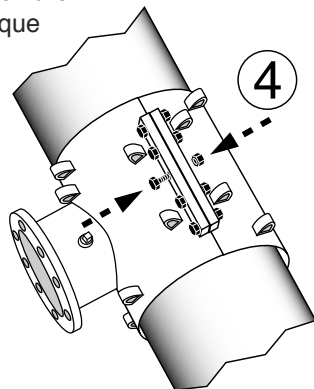

Step 5 • Assemble the end rings around the pipe as they were shipped from the factory. The bolts connecting the end ring halves should be tightened to ft-lbs. The end rings should be rotated around the pipe so that the joints in the rings are as far as possible from the sidebars.

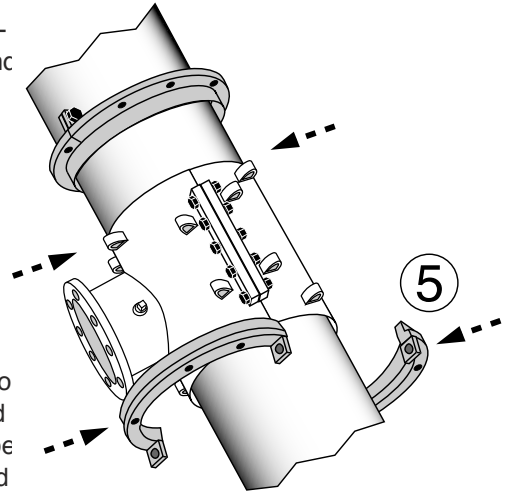

Step 6 • Lubricate the gaskets with a suitable gasket lubricant. Wrap end gaskets around pipe and push into the gasket recesses in the end rings. Overlap of gasket ends by 1/2" is acceptable. The gasket joints should be kept six to nine inches from the joints of the sleeve halves.

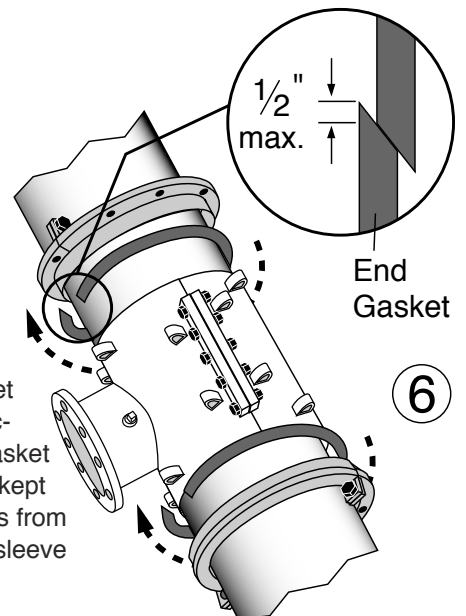

Installation Instructions continued on back

FTS 425 (continued from front)

Step 7 • Insert the bolts through the end ring and the anchor loops and tighten hand tight. Tighten the bolts evenly to 70 ft-lbs.

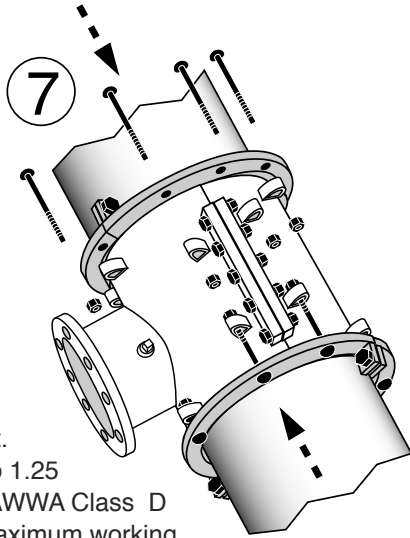

Step 8 • Remove test plug and pressure test assembly to determine a tight joint. Test at pressure up to 1.25 times flange rating. AWWA Class D flanges, 4-12 inch, maximum working pressure is 175 psi and a maximum test pressure of 220 psi. For flange sizes 14" and larger the maximum working pressure is 150 psi and the maximum test pressure is 188 psi.

Step 9 • Attach and support the tapping valve. Attach the tapping machine. The tapping machine shall be supported until the tap is completed.

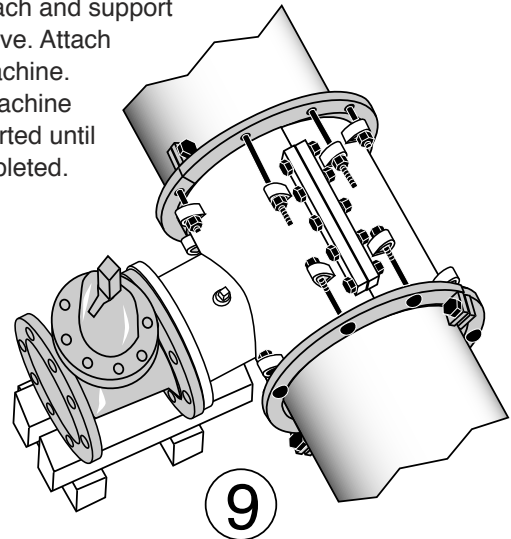

CAUTION: The tapping sleeve is not designed to support the weight of the tapping valve or machine. The seal between the pipe and the tapping sleeve may be compromised if the tapping sleeve is allowed to rotate on the pipe.

PRECAUTIONS

1. Check diameter of pipe to make sure you are using the correctly sized sleeve.
2. Clean pipe to remove as much dirt and corrosion as possible from the surface.
3. Make sure no foreign materials stick to the gasket as it is brought around the pipe, nor become lodged between gasket and pipe as nuts are tightened.
4. Avoid loose fitting wrenches, or wrenches too short to achieve proper torque.
5. Keep threads free of foreign material to allow proper tightening.
6. Bolts are often not tightened enough when a torque wrench is not used. Take extra care in this situation to make sure proper tightening occurs.
7. Install tapping sleeve with outlet in the direction of the branch pipe. Do not spin or rotate tapping sleeve on pipe.
8. Pressure test for leaks before tapping pipe.
9. Backfill and compact carefully around sleeve.
10. Caution, when reinstalling parts with stainless steel hardware there may be a loss in pressure holding ability due to worn or damaged threads during the original installation.
11. For personal safety reasons, do not use a compressible fluid (such as air) to check for water tightness.

COMMON INSTALLATION PROBLEMS

1. Not enough torque on bolts.
2. Rocks or debris cutting gasket.
3. Dirty threads on bolts or nuts.
4. Allowing tapping sleeve to support the cantilever load of the valve, tapping machine or pipe.
5. Not using the proper size sleeve for the pipe.
6. Not using thrust block or other form of restraint.
7. Spinning or rotating tapping sleeve on the pipe.
8. Trimming gaskets before or after bolting halves together.

NOTE: Tapping sleeves are designed for sealing purposes only, not structural support or restraint.