

INSTALLATION INSTRUCTIONS

Read installation instructions first before installing. Check parts to ensure that no damage has occurred during transit and that no parts are missing. Also check the diameter of the pipe and the range marked on the tapping sleeve to ensure you have the proper size.

FTS 435 Tapping Sleeve for Concrete Pipe

Step 1 • Clean the pipe in the area where the tapping sleeve is to be installed. Remove all irregularities that are above the contour of the pipe.

Step 2

• Position the body on the pipe as it will be installed. Mark the pipe inside the outer neck where the mortar coating will be removed. Remove the mortar coating in the marked area down to the steel wires.

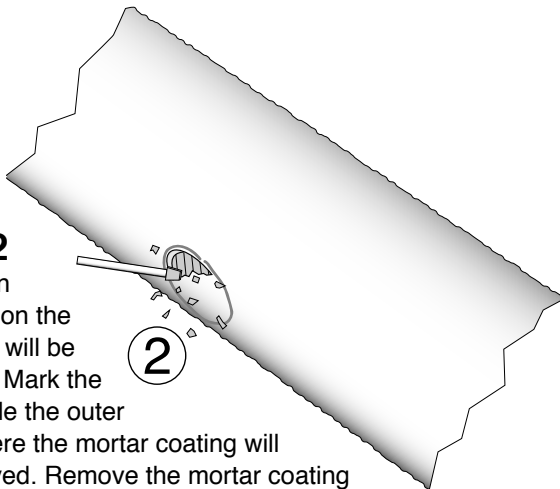

Step 3 • Install the body of the tapping sleeve on the pipe with the grout horns up. The outer neck should be centered over the bared cylinder.

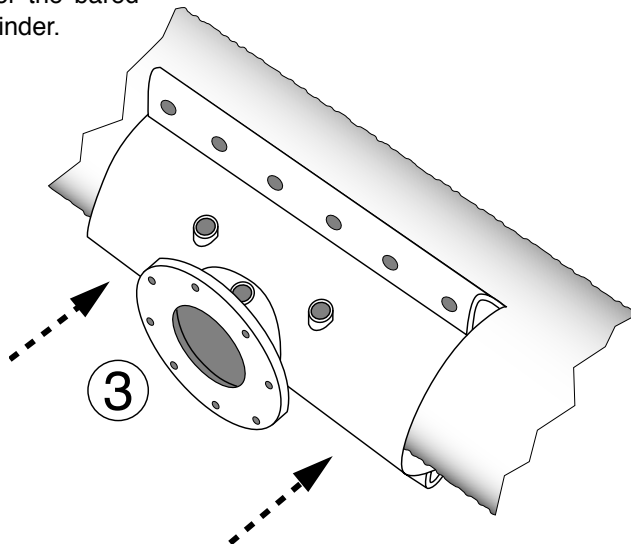

Step 4

• Install the straps and tighten the bolts until the foam grout seal is in contact with the pipe all around the body and the outer neck. Do not over-tighten.

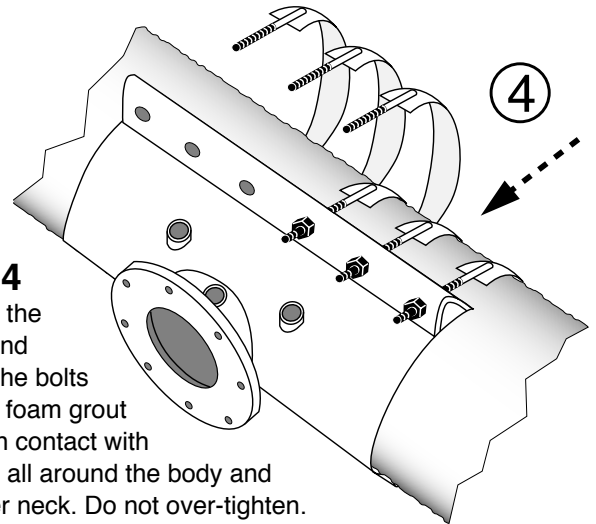

Step 5

• Pour liquid grout into the grout horns on the body of the sleeve. Tap the body of the sleeve to settle the grout between the I.D. of the sleeve and the O.D. of the pipe. Allow time for the grout to cure.

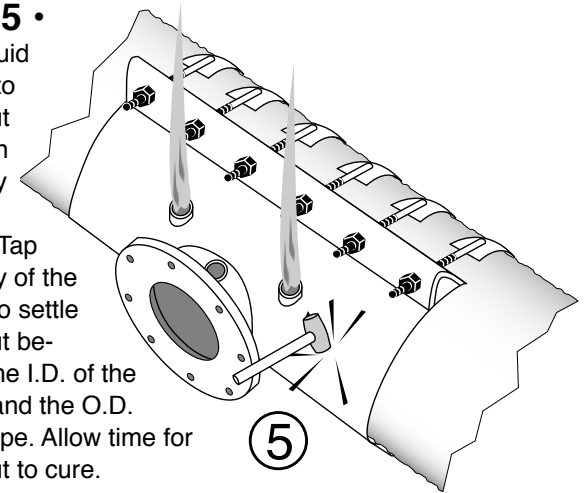

Step 6 • After the grout has cured, tighten the strap bolts evenly to 50 to 60 ft-lbs. torque. Cut and remove the steel reinforcing wires, taking care not to damage the pipe. Make certain that sufficient area over the cylinder has been cleared to provide clearance for the gasket ring and that the surface of the cylinder is smooth and clean.

Installation Instructions continued on back

FTS 435

Continued from front

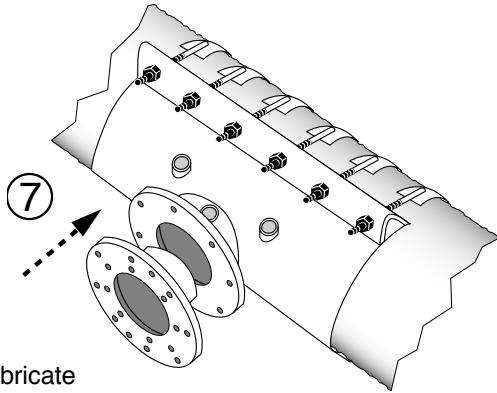

Step 7 • Lubricate the gasket and pipe surface with a suitable gasket lubricant. Insert the inner neck into the outer neck with the contour of the gasket ring oriented to match the contour of the pipe. Insert the draw studs through the tapping flange and the securing flange. Tighten the draw studs evenly around the flange to compress the gasket so there is approximately 1/8" between the gasket ring and the pipe cylinder.

Step 8 • Insert the set screws into the securing flange and tighten to 30 ft-lbs. torque.

Step 9 • Test the assembly. Attach and support a tapping valve or attach a blind flange to the tapping flange with the proper size bolts or studs. The tapping machine shall be supported until the tap is completed. Pressurize with water. Test pressure depends on the pressure inside the pipeline at the time of testing. When the pipeline pressure is less than or equal to 15 psi, the test pressure is 20 psi. When the pipeline pressure is greater than 15 psi, the maximum test pressure is either 1.5 times the pipeline pressure or 180 psi, whichever is less.

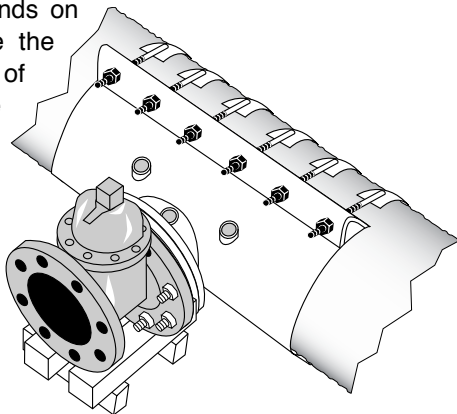

Step 10 • Fill the annular space between the inner and outer necks and the tapping and securing flanges with grout.

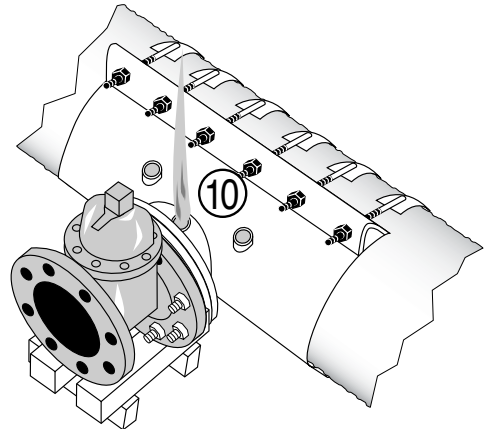

Step 11 •
Client's option: When the tap is complete, coat the entire assembly with concrete mortar.



Caution: Caution, when reinstalling parts with stainless steel hardware there may be a loss in pressure holding ability due to worn or damaged threads during the original installation.

For personal safety reasons, do not use a compressible fluid (such as air) to check for water tightness.



Caution: Extreme care must be taken during testing to avoid damaging the pipe. Do not over pressurize during testing.