

# INSTALLATION INSTRUCTIONS

Read installation instructions first before installing. Check parts to ensure that no damage has occurred during transit and that no parts are missing. Also check the diameter of the pipe and the range marked on the clamp to ensure you have the proper size.

## Style SS1, SS2 & SS3 Transition Clamp Coupling for Sewer

**Step 1** • Check the Clamp parts to insure that no damage has occurred during transit and that no parts are missing. Also check the diameter of the pipe and the range marked on the clamp to insure you have the proper size.

**Step 2** • Thoroughly clean pipe surface that will be covered by the clamp. Lubrication should be used on rough surface pipe (Iron and A/C) to assure proper seal.

**Step 3** • Place reference marks on pipe an equal distance from each pipe end slightly wider than the clamp for centering clamp over the pipe ends.

**Step 4** • Wrap bushing material around smaller pipe being joined. The bushing material is cut to the precise length for each job. When bushing is completely rapped around the smaller pipe it will have an OD greater than the larger pipe. The extra bushing material is to help compensate for the compression of the gasket material.

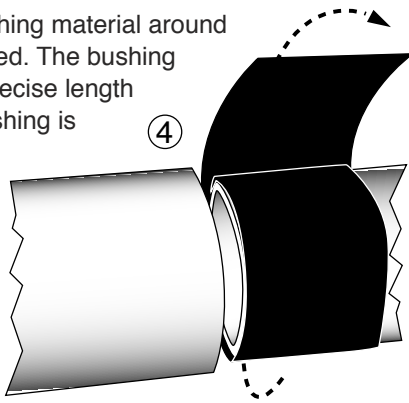

**Step 5** • Back off nuts to the end of the bolt – DO NOT REMOVE. Separate clamp and wrap it around bushing and pipe, positioning it so the bolts are in a convenient place for assembly and tightening.

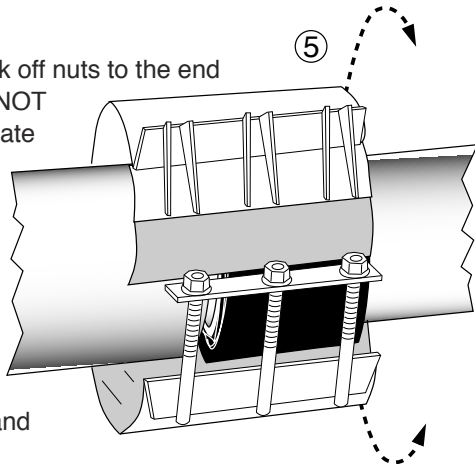

**Step 6** • Slide lifter bar up the receiver lug profile and snap into place over the sidebar edge. Make sure the gasket tails are not folded under, but are laying flat around the pipe and bushing. Check reference marks to ensure clamp is in position.

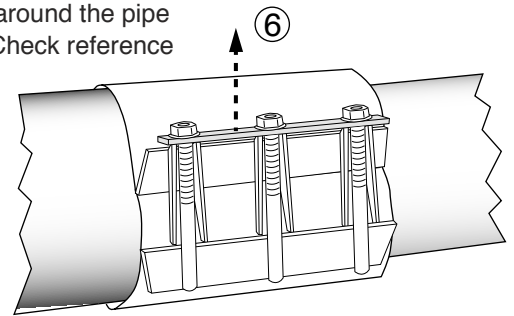

**Step 7** • Tighten all nuts evenly in 20 ft-lbs. increments. Use a wrench with at least a 12 inch handle.

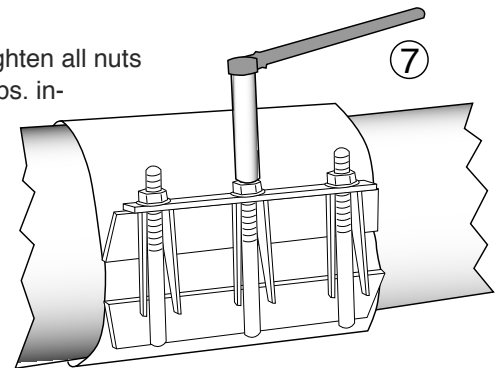

Nom. Pipe Diameter	Torque
4" and below	30-35 ft-lbs.
6" and above	75-85 ft-lbs.

**Note:**

35 ft-lbs. torque = 12" wrench w/35 lbs. force  
85 ft-lbs. torque = 12" wrench w/85 lbs. force

For best results, wait 10 minutes and then re-tighten to proper torque.

**Note:** Sewer clamp couplings do not provide protection against axial force. Suitable anchorage should be provided.

## Style SS1, SS2 & SS3 Transition Clamp Coupling for Sewer

### PRECAUTIONS

1. Check diameter of pipe to make sure you are using correctly sized clamp.
2. Clean pipe to remove as much dirt and corrosion as possible from the surface.
3. Make sure no foreign material comes between the gasket and the pipe as the nuts are being tightened.
4. Avoid loose fitting wrenches, or wrenches too short to achieve proper torque on the nuts.
5. Keep threads free of foreign material to facilitate tightening.
6. Bolts are often not tightened enough when a torque wrench is not used. Take extra care in this situation to make sure that proper tightening occurs.
7. Pressure test for leaks before backfilling.
8. Be sure to use all the bushing material provided.
9. When reinstalling parts with stainless steel hardware there may be a loss in pressure holding ability

### COMMON INSTALLATION PROBLEMS

1. Bolts are not tightened to the proper torque.
2. Rocks or debris between pipe and gasket.
3. Dirt on threads of bolts or nuts.
4. Repair clamp too small for the size of damage to pipe.
5. Repair clamp not centered over damaged portion of pipe.
6. Repair clamps should not be used as couplings.
7. Gaps between sections are not equal (SS2 and SS3).