

INSTALLATION INSTRUCTIONS

Read installation instructions first before installing. Check parts to ensure that no damage has occurred during transit and that no parts are missing. Also check the diameter of the pipe and the range marked on the clamp to ensure you have the proper size.

LIMITATIONS: For product limitations see reverse side. For more detailed information see the HDPE Products section of the Romac Product Catalog, or phone Romac Engineering Department at 1-800-426-9341.

Style SS1-H, SS2-H & SS3-H Stainless-Seal Pipe Repair Clamp for HDPE

Spring Washers must be installed in these configurations

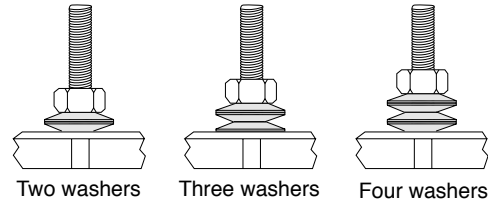

Step 1 • Thoroughly clean pipe surface that will be covered by the clamp.

Step 2 • Place reference marks on the pipe in line with the crack or hole in the pipe slightly wider than the clamp. If clamp is being placed over a weld, the weld must be ground flush.

If using tapped repair clamp, be sure that the outlet is positioned in the area where the tap is to be done.

Step 3 • Back off nuts to end of bolts, but **DO NOT REMOVE THEM.**

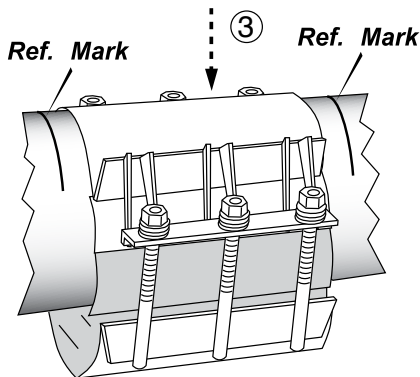

SS1H: Separate clamp and wrap it around the pipe.

SS2H and SS3H: Separate the clamp sections. Center one of the sections over the crack or hole being repaired.

If possible, position one of the sections around the pipe so the bolts and receiver lugs are in a convenient place to assemble and tighten.

Note: If necessary because of flowing water, Steps 3 and 4 can be performed beside the pipe crack or hole. Slide the clamp over the break after the lifter bars have been snapped into place.

Step 4 • Slide lifter bars up the receiver lug profile and snap into place over the side-bar edge.

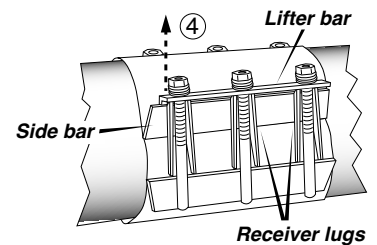

Make sure the gasket tails are not folded under, but are laying flat around the pipe.

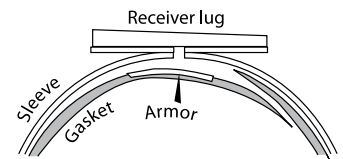

Step 5 • Tighten all nuts evenly in 20 ft-lbs. increments. Start in the center and work toward each end. Alternate from one side to the other to equalize the gap between halves, keeping torques as evenly balanced as possible. Use a wrench with at least a 12" handle.

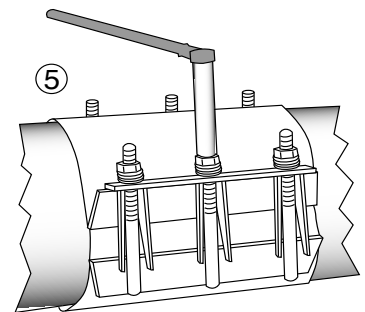

For SS2-H and SS3-H repair clamps, maintain an equal gap between the sidebars.

Nom. Pipe Diameter	Torque
4" and below	30-40 ft-lbs.
6" and above	75 ft-lbs.

Note:
35 ft-lbs. = 12" wrench w/ 35 lb. force
75 ft-lbs. = 12" wrench w/ 75 lb. force

For best results, wait 10 minutes and then retighten to proper torque.

If using tapped repair clamp, pressure test before tapping. Backfill and compact carefully around clamp and service line.

INSTALLATION INSTRUCTIONS

Style SS1-H, SS2-H & SS3-H Stainless-Seal Pipe Repair Clamp for HDPE

PRECAUTIONS

1. Check diameter of pipe to make sure you are using the correctly sized clamp.
2. Clean pipe to remove as much dirt and corrosion as possible from the surface.
3. Place a mark on the pipe to reference the leak. After installation use this mark to assure that the clamp has been properly positioned.
4. Make sure no foreign materials stick to the gasket as it is brought around the pipe, nor become lodged between gasket and pipe as nuts are tightened.
5. Avoid loose fitting wrenches, or wrenches too short to achieve proper torque.
6. Keep threads free of foreign material to facilitate tightening.
7. Bolts are often not tightened enough when a torque wrench is not used. Take extra care in this situation to make sure proper tightening occurs.
8. Always pressure test for leaks before backfilling.
9. Backfill and compact carefully around clamp.
10. When reinstalling parts with stainless steel hardware there may be a loss in pressure holding ability due to worn or damaged threads during the original installation.

COMMON INSTALLATION PROBLEMS

1. Bolts are not tightened to the proper torque.
2. Rocks or debris cutting gasket.
3. Dirt on threads of bolts or nuts.
4. Installing in the heat of the day.
5. Not grinding welds flush.

PRODUCT LIMITATIONS

High Density Polyethylene Pipe (HDPE) has a lower modulus of elasticity and higher coefficient of thermal expansion than other pipe materials. These properties cause HDPE pipe to expand and contract much more from changes in temperature and/or pressure than other piping materials. Because of these and other properties, great care must be taken when installing conventional fitting on HDPE.

This product has been provided with the proper number of spring washers for the conditions described in the following limitations.

HDPE LIMITATIONS:

- Pipe must be manufactured in accordance with AWWA Standard C906-90.
- Operating temperatures are limited to 85° F maximum and 32° F minimum.
- Operating pressure is limited to 150 psi or the rating of the pipe, whichever is less.
- Pipe systems must be designed to compensate for pipe movement so as to prevent fittings from migrating or rotating on the pipe.
- Products are intended for use in underground service only.
- Products are not to be used on pressurized HDPE pipe with an SDR greater than 26.



ROMAC CANNOT WARRANT PRODUCTS USED IN APPLICATIONS THAT ARE OUTSIDE ONE OR MORE OF THESE LIMITATIONS. CONTACT ROMAC'S ENGINEERING DEPARTMENT AT 1-800-426-9341 IF YOU HAVE QUESTIONS ABOUT THE USE OF OUR PRODUCTS ON HDPE PIPE.

HDPE PRECAUTIONS:

Try always to install fittings when pipe is at its coldest.

Be sure that spring washers are stacked properly (see drawing at right).

This product is designed for a 53° F temperature range maximum.

