



INSTALLATION INSTRUCTIONS

Read installation instructions first before installing. Check parts to ensure that no damage has occurred during transit and that no parts are missing. Also check the diameter of the pipe and the range marked on the clamp to ensure you have the proper size.

LIMITATIONS: For product limitations see reverse side. For more detailed information see the HDPE Products section of the Romac Product Catalog, or phone Romac Engineering Department at 1-800-426-9341.

Style SST-H Stainless Steel Tapping Sleeve for HDPE Pipe

Spring Washers must be installed in these configurations

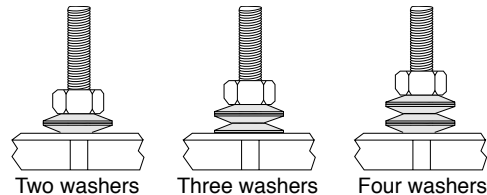

Step 1 • Before installing tapping sleeve, clean pipe thoroughly, removing all dirt, rock, scale and foreign material in area where tapping sleeve is to be installed.

Step 2 • Remove nuts and lifter bars from bolts, being careful not to lose washers.

Step 3 • Place outlet-half of sleeve on pipe and move into position, being careful not to fold under the gasket.

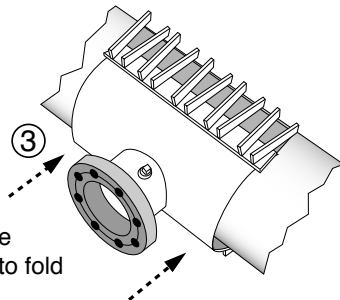

Step 4 • Bring back half of sleeve into position, making sure bolts are located between mating receiver lugs on the sleeve outlet half. Check gasket edges along sleeve top and bottom halves to be sure they overlap and are not folded under. Also check that the armor is between the back half and pipe.

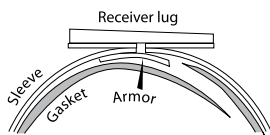
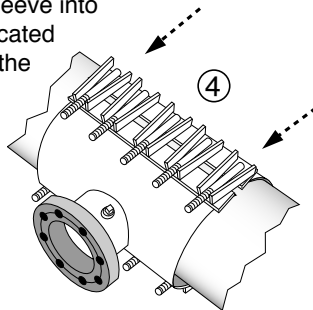

Step 5 • Replace lifter bars first, and then washers and nuts.

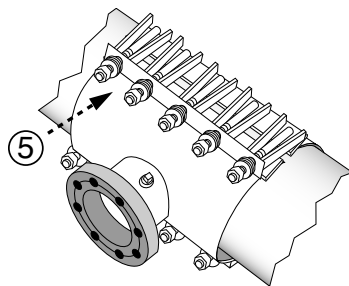

Step 6 • Well-tightened nuts are important to ensure a full-circle seal. Tighten nuts, starting with center bolts, alternating on either side of the sleeve. Gap between sleeve halves on either side should be the same when nuts are fully torqued.

Tighten $\frac{5}{8}$ " nuts evenly in 25 ft-lb. increments to a minimum of 75 ft-lbs. (this is approximately a 56 lb. pull on a 16" wrench). Tighten $\frac{1}{2}$ " nuts to 60 ft-lbs. For best results, wait at least 10 minutes, then re-tighten.

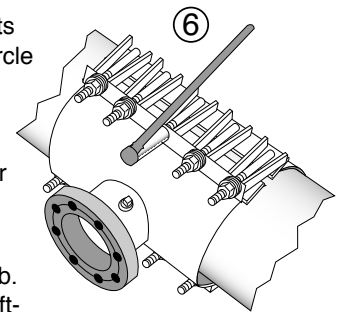

Step 7 • Bolt tapping valve to flange. The inside of the flange accepts the tapping valve locator. The flange gasket, which is glued in place, is the only gasket needed. Block or otherwise support valve.

Step 8 • Remove test plug and connect test apparatus to tapping sleeve assembly. When properly installed, the SST-H can work at pressures up to 150 psi. Ensure line is pressurized before testing. Test pressures should not exceed line pressure or 150 psi, whichever is less. If assembly does not leak, proceed with installation and tap. If assembly leaks, check bolts to be sure the nuts have been torqued to at least 75 ft-lbs. and then retest assembly.

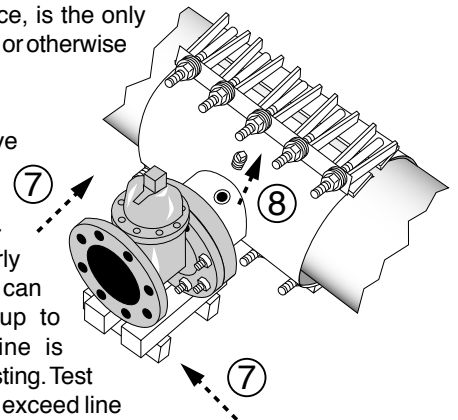

Step 9 • Block or otherwise support the tapping machine during the tap, then be sure and support the pipe being connected to the valve.

INSTALLATION INSTRUCTIONS

Style SST-H

PRECAUTIONS

1. Check diameter of pipe to make sure you are using the correctly sized sleeve.
2. Clean pipe to remove as much dirt and corrosion as possible from the surface.
3. Make sure no foreign materials stick to the gasket as it is brought around the pipe, nor become lodged between gasket and pipe as nuts are tightened.
4. Avoid loose fitting wrenches, or wrenches too short to achieve proper torque.
5. Keep threads free of foreign material to facilitate tightening.
6. Bolts are often not tightened enough when a torque wrench is not used. Take extra care in this situation to make sure proper tightening occurs.
7. Pressure test for leaks before backfilling.
8. Backfill and compact carefully around clamp.
9. When reinstalling parts with stainless steel hardware there may be a loss in pressure holding ability due to worn or damaged threads during the original installation

COMMON INSTALLATION PROBLEMS

1. Bolts are not tightened to the proper torque.
2. Rocks or debris cutting gasket.
3. Dirt on threads of bolts or nuts.
4. Installing in the heat of the day.
5. Tapping sleeve not supported.

PRODUCT LIMITATIONS

High Density Polyethylene Pipe (HDPE) has a lower modulus of elasticity and higher coefficient of thermal expansion than other pipe materials. These properties cause HDPE pipe to expand and contract much more from changes in temperature and/or pressure than other piping materials. Because of these and other properties, great care must be taken when installing conventional fitting on HDPE.

This product has been provided with the proper number of spring washers for the conditions described in the following limitations.

HDPE LIMITATIONS:

- Pipe must be manufactured in accordance with AWWA Standard C906-90.
- Operating temperatures are limited to 85° F maximum and 32° F minimum.
- Operating pressure is limited to 150 psi or the rating of the pipe, whichever is less.
- Pipe systems must be designed to compensate for pipe movement so as to prevent fittings from migrating or rotating on the pipe.
- Products are intended for use in underground service only.
- Products are not to be used on pressurized HDPE pipe with an SDR greater than 17.



ROMAC CANNOT WARRANT PRODUCTS USED IN APPLICATIONS THAT ARE OUTSIDE ONE OR MORE OF THESE LIMITATIONS. CONTACT ROMAC'S ENGINEERING DEPARTMENT AT 1-800-426-9341 IF YOU HAVE QUESTIONS ABOUT THE USE OF OUR PRODUCTS ON HDPE PIPE.

HDPE PRECAUTIONS:

Try always to install fittings when pipe is at its coldest.

Be sure that spring washers are stacked properly (see drawing at right).

This product is designed for a 53° F temperature range maximum.

