

Transmate deChlorinator™

Manual



Thank you for your purchase of the Transmate DeChlorinator. Please read and understand this short operation manual. Our goal is to serve you, our customer. If you have any questions or improvement suggestions please call us at 1-800-426-9341.

TABLE OF CONTENTS

Solution Mixing	pg. 2
Components	pg. 3
Set-Up	pg. 4
Operation.....	pg. 5
Troubleshooting	pg. 6

deChlorinator Operations Manual
9/27/01Rev.



Romac Industries, Inc.

21919 20th Avenue SE • Suite 100 • Bothell, WA 98021

800 426 9341 • 425 951 6200 • Fax 425 951 6201 • www.romacindustries.com

Transmate deChlorinator™

Solution Mixing

Vita-D-Chlor FEED SOLUTION MIXING AND FEED SOLUTION VALVE SETTING CHARTS

This chart is good for water flow between 175 - 900 gpm

If... Cl.(ppm, mg/l) value	Then add... Vita-D-Chlor cups per 5 gal water	Set Control Valve on... for maximum Cl.
0 - .5	1/4 cup	2
.5 - 1	1/2 cup	2
1 - 1.5	1/2 cup	3
1.5 - 10	5 cups	2
10 - 30	15 cups	2
30 - 50	15 cups	3
50 - 150	25 cups	Full open
150 - 200	34 cups	Full open

If you	You will	And	Keep in mind
Turn control valve toward 0	Decrease the flow of feed solution	Increase the amount of time between solution batch mixing.	You might not be adding enough feed solution to dechlorinate the water.
Turn control valve toward full open	Increase the flow of feed solution	Decrease the amount of time between solution batch mixing.	You might be using too much V-D-C mix and overdosing the discharge water.
Increase the V-D-C mix amount	Be able to decrease the feed solution flow	Increase the amount of time between solution batch mixing.	More V-D-C will be used and less time spent making solution batches.
Decrease the V-D-C mix amount	Have to increase the feed solution flow	Decrease the amount of time between solution batch mixing.	Less V-D-C used. More time spent making solution batches.

FEED SOLUTION CONSUMPTION CHART

Consumption in gallons per (how many minutes to empty a 5 gallon bucket) hour
FLOW RATE in gallons per minute (GPM)

Needle Valve Setting	150-200 GPM	200-300 GPM	300-400 GPM	400-600 GPM	600+ GPM
FULL OPEN	22 gph (14 min)	45 gph (7min)	64 gph (5 min)	90 gph (3 min)	110 gph (3 min)
3 turns	17 gph (18 min)	34 gph (9 min)	48 gph (6 min)	68 gph (4 min)	83 gph (4 min)
2 turns	6 gph (55 min)	12 gph (27 min)	16 gph (19 min)	23 gph (13 min)	28 gph (11 min)
1 turn	4 gph (1.5 hour)	7 gph (44 min)	10 gph (31 min)	14 gph (22 min)	17 gph (18 min)

NOTE: Mixed solution cannot be stored overnight. It will decrease in potency and will not dechlorinate.

Transmate deChlorinator™

Components

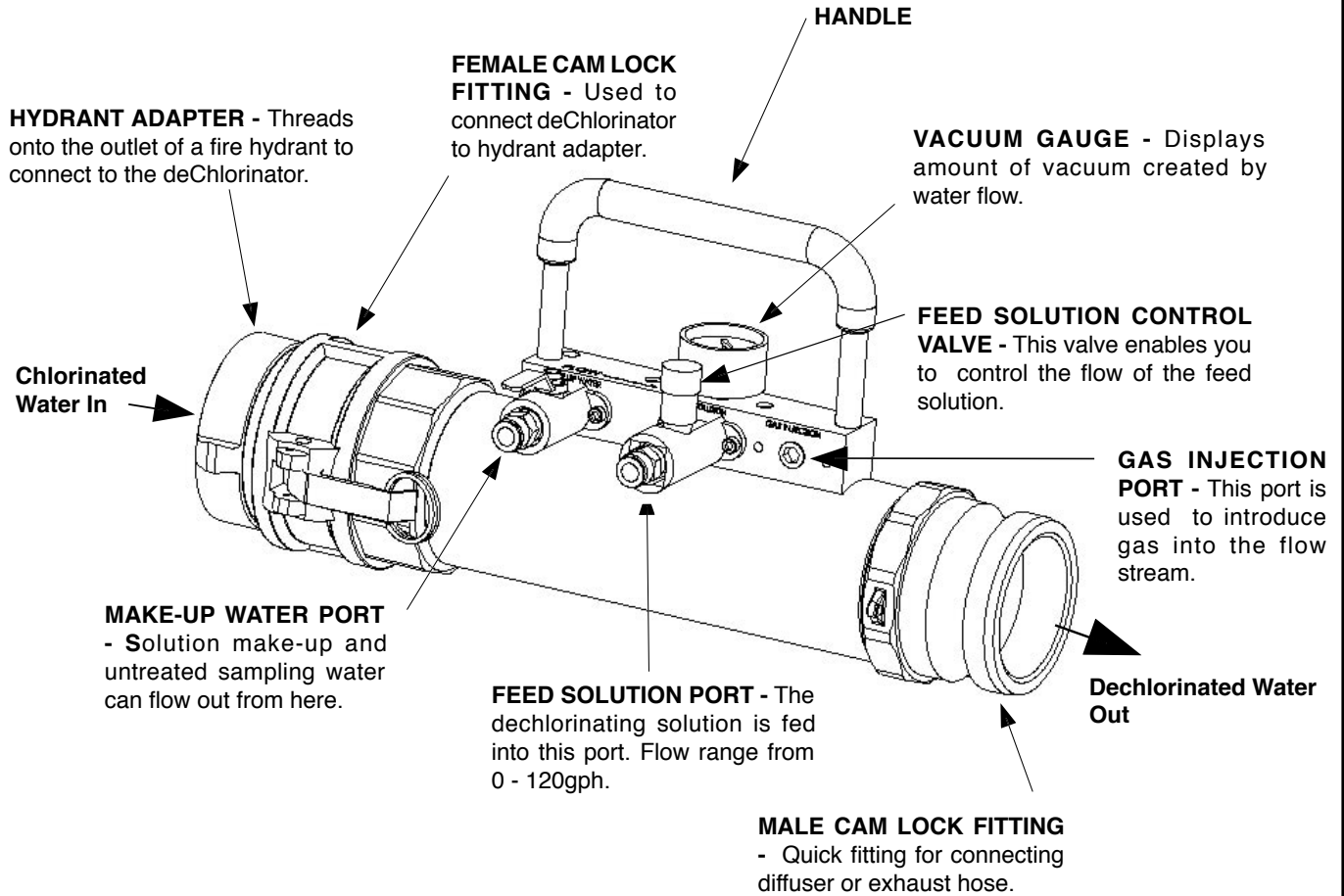

Transmate deChlorinator™

Set-Up

Connect the hydrant adapter, control valve, or extension hose directly to the hydrant. Thread the hydrant adapter onto the end of the control valve or extension hose if used. This step is done regardless of which set-up is used.

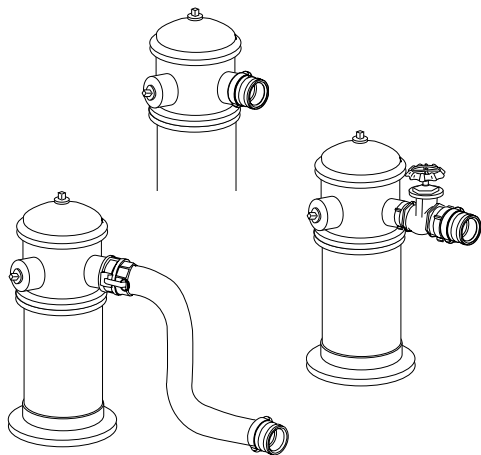

NOTE: When using deChlorinator at very high flows, be sure to place pin in hole (shown below) to prevent the camlock from blowing off.

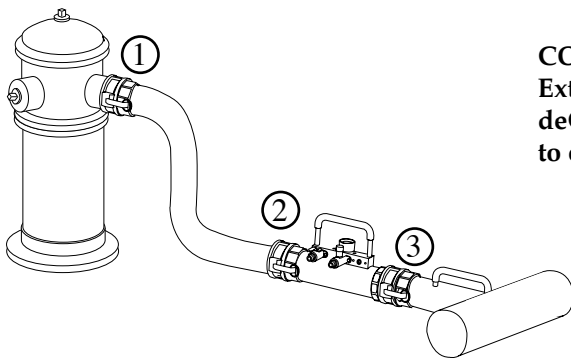
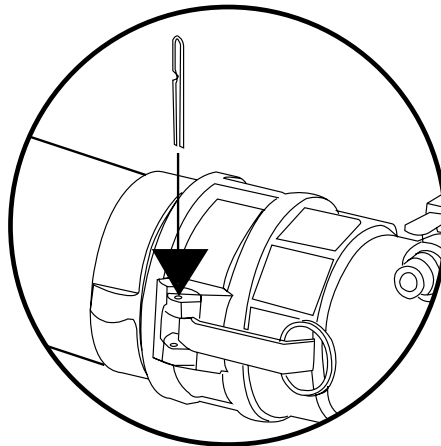

CONFIGURATION #1

Extension hose connected to the hydrant with the deChlorinator on the ground and a diffuser connected to outlet.

- ① Connect female end of extension hose to hydrant or hydrant adapter. In this case the hydrant adapter is connected to the end of the extension hose.
- ② Connect female end of deChlorinator to male end of extension hose.
- ③ Connect diffuser to male end of deChlorinator.

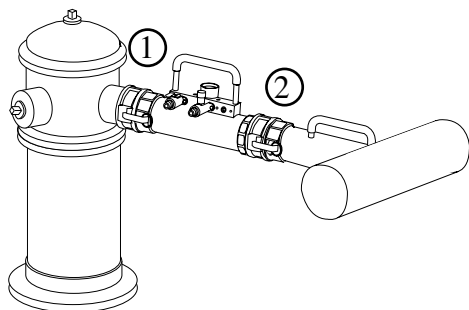

CONFIGURATION #2

deChlorinator connected to a hydrant, and a diffuser connected to the deChlorinator outlet.

- ① Connect female end of deChlorinator to male end of hydrant adapter.
- ② Connect diffuser to male end of deChlorinator.

Transmate deChlorinator™

Set-Up

CONFIGURATION #3

This configuration is used when you wish to use the deChlorinator unit between hoses leading to the hydrant adapter and diffuser.

NOTE: Keep in mind the extension hose needs to be extended straight out with no kinks or bends.

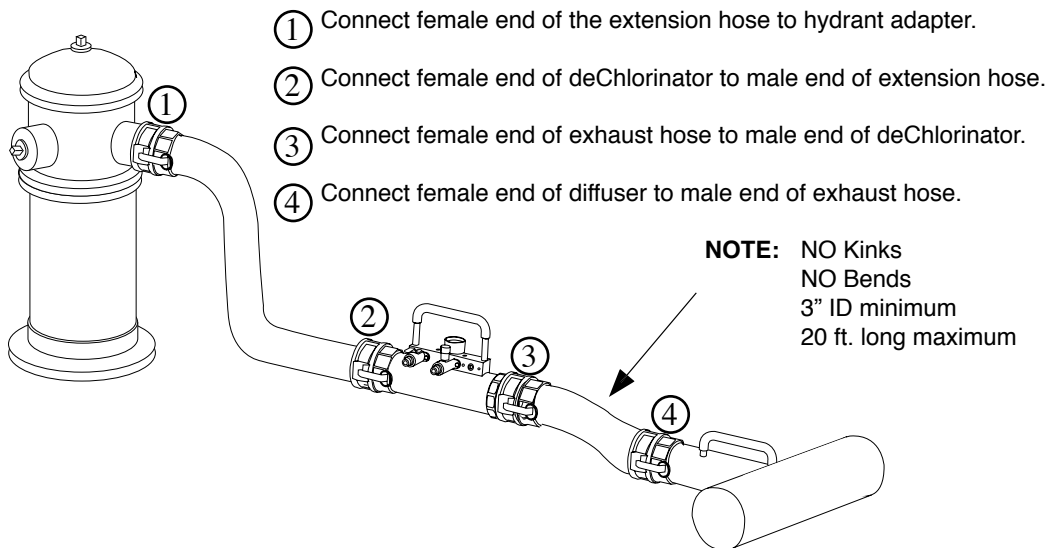

CONFIGURATION #4

If you want to connect the deChlorinator to a fire hydrant, using 20 feet of 3" ID exhaust hose connected to the deChlorinator outlet. Follow these steps.

NOTE: It is NOT recommended that the deChlorinator be connected directly to a hydrant with an exhaust hose connected to the outlet for use under 300 gpm.

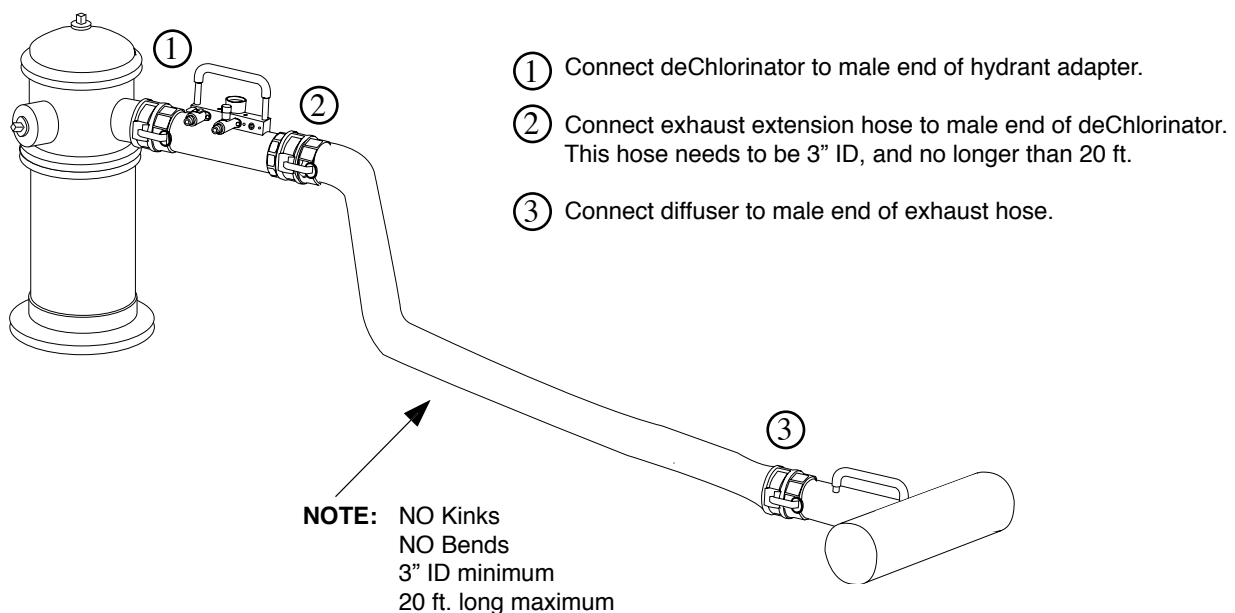

Transmate deChlorinator™

Operation

Once you have completed your set-up, the last steps are simple. This section of the manual deals with your deChlorinator's gauges, valves and hoses. It will outline and explain the flow direction, vacuum gauge and feed solution valve.

The flow direction for dechlorinating is clearly marked on the top of your deChlorinator.

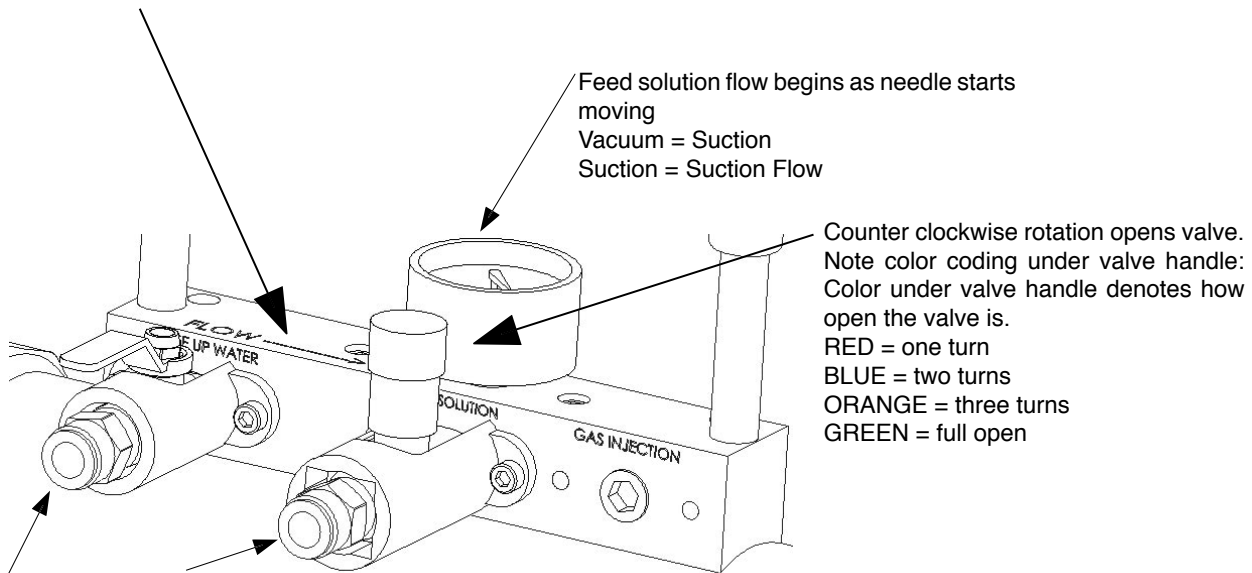

To install tubes on the Make Up Water Port and the Feed Solution Ports, just push tube in.

Removal is just as easy. To remove tubes, push in on outside collar while pulling away from unit on tube. Be sure not to force or overpull on the fittings.

- Connect the sampling tube to MAKE-UP WATER PORT

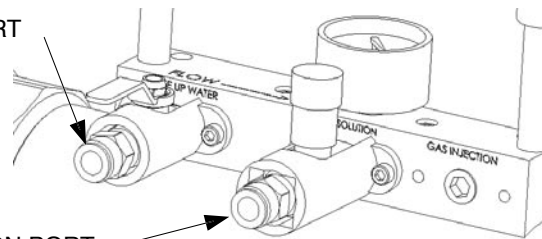

- Connect the feed solution tube to the FEED SOLUTION PORT.
- Connect the opposite end of the feed solution hose into the solution control valve located at the bottom of the bucket.

Transmate deChlorinator™

Operation

Now that you have the feed tubes connected properly you're ready to start the flow of water.

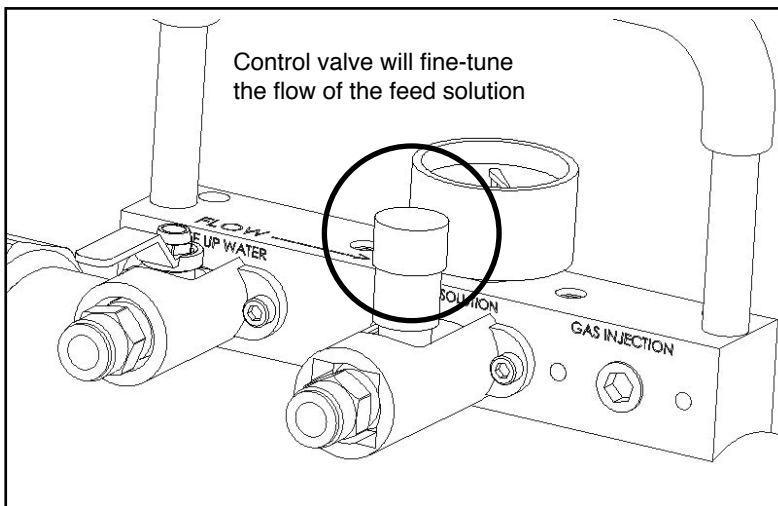
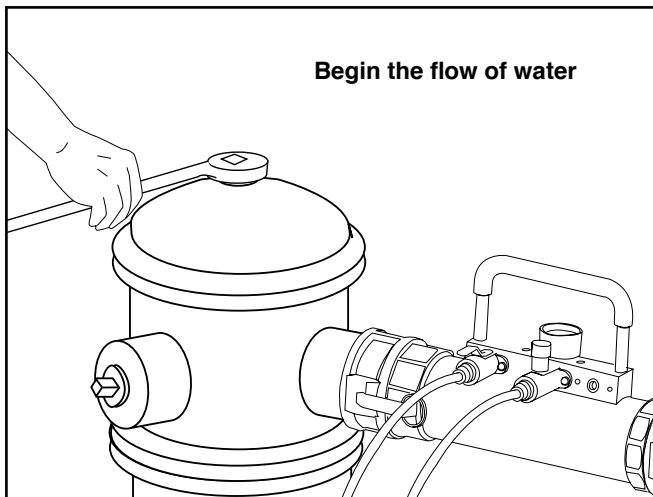

The feed solution flow can be fine-tuned with the control valve. This allows just enough dechlorinating solution to be fed to the water flow and extends the time between making up more batches of feed solution.

NOTE: Frequently check chlorine content of the discharge water and adjust the feed solution as needed.

Transmate deChlorinator™

Troubleshooting

Problem	Possible Solutions
deChlorinator not producing enough suction	<ul style="list-style-type: none">• Open up feed solution valve. Rotate valve in counterclockwise direction to open.• Increase water flow rate.• Check for blockage.• Elevate bucket above deChlorinator. This will create a siphon.• You might have too much exhaust hose length, too small an ID on your exhaust hose, or too much restriction on your diffuser. Shorten the exhaust hose length, and increase the exhaust hose ID.
Make-up/Sampling water not producing enough water flow	<ul style="list-style-type: none">• Increase the amount of water flow, by opening hydrant more
Outlet water not dechlorinated.	<ul style="list-style-type: none">• Increase the amount of dechlorinating reagent by scooping more into the feed solution mix.
You're at zero residual Cl, but you suspect you're using too much dechlorinating agent	<ul style="list-style-type: none">• Slowly rotate the needle valve in the clockwise direction until you see just a trace of Cl., then rotate back half a turn. Check to make sure your residual is at zero.