

B2128-A

REVISIONS			
REV.	DESCRIPTION	DATE	APPROVED
0	INITIAL RELEASE	12/27/02	NST III
1	CHANGED NOTES TO REFLECT STD EPOXY & ADDED STAINLESS STEEL AVAILABILITY	1/31/03	NST III
2	ADDED O-RING GASKET DIAMETER "G" TO TABLE	3/29/05	NST III
3	ADDED O-RING GASKET TO SIZES 14"-24". ADDED DIMENSIONS TO "G"	12/16/11	SH

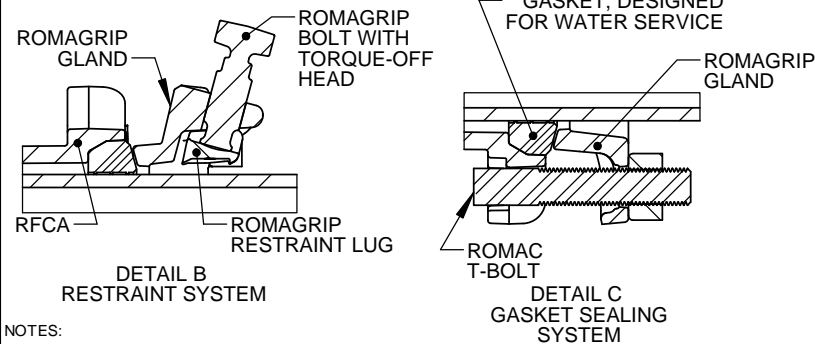
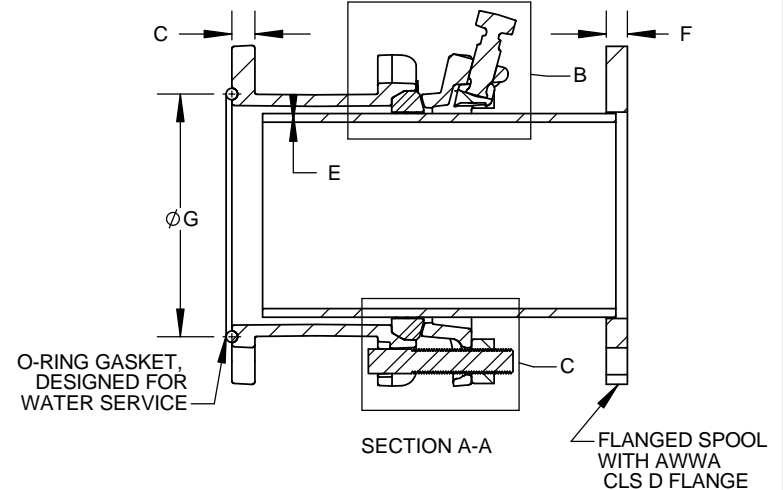
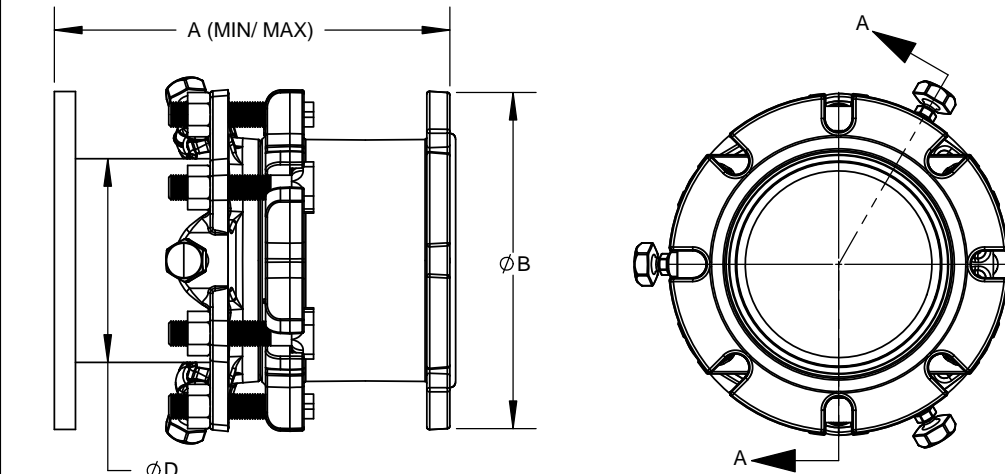

NOM SIZE	DIMENSIONS						MAX DEFL. (DEG)	T-BOLTS		FLANGED SPOOL			RFCA	WGT (LBS)	
	LENGTH "A"			FLG OD "B"	FCA FLG THK "C"	QTY		SIZE	LENGTH	OD "D"	PIPE THK "E"	FLG THK "F"			GSKT DIA "G"
	NOM.	MIN	MAX												
3	11.50	10.00	13.00	7.5	0.75	2.0	4	5/8"	3.75	3.50	0.22	0.63	4.66	33	
4	12.75	11.00	14.50	9.0	0.75	3.5	4	3/4"	4.25	4.50	0.24	0.63	6.00	46	
6	13.50	11.50	15.50	11.0	0.75	3.5	6	3/4"	4.25	6.63	0.28	0.69	7.90	68	
8	13.50	11.50	15.50	13.5	0.75	3.3	6	3/4"	4.25	8.63	0.32	0.69	10.00	94	
10	14.75	12.50	17.00	16.0	0.75	3.0	8	3/4"	4.25	10.75	0.37	0.69	12.40	143	
12	14.75	12.50	17.00	19.0	0.81	3.0	8	3/4"	4.25	12.75	0.38	0.81	15.12	193	
14	19.25	16.75	21.75	21.0	1.38	2.0	10	3/4"	4.50	15.30	0.38	0.94	16.38	297	
16	19.25	16.75	21.75	23.5	1.44	2.0	12	3/4"	4.50	17.40	0.38	1.00	18.48	352	
18	20.25	17.75	22.75	25.0	1.45	1.5	12	3/4"	4.50	19.50	0.38	1.06	20.57	390	
20	20.25	17.75	22.75	27.5	1.47	1.5	14	3/4"	4.50	21.60	0.38	1.13	22.63	457	
24	21.25	18.75	23.75	32.0	1.50	1.5	16	3/4"	5.00	25.80	0.38	1.25	26.88	569	

NOTES:

- NSF 61 CERTIFIED COATING: FUSION BONDED EPOXY IS STANDARD. OTHER COATINGS AVAILABLE UPON REQUEST.
- CUSTOMER MUST CONFIRM LENGTH OF ASSEMBLY TOLERANCE "A".
- PRESSURE RATED UP TO FLANGES PROVIDED. 3-12" AWWA CLS D 175 PSI WORKING, 263 PSI TEST. 14"-24" AWWA CLS D 150 PSI WORKING, 225 PSI TEST. HIGHER PRESSURE RATINGS AND FLANGES AVAILABLE.
- ROMAC DJ405 DISMANTLING JOINT WILL ALLOW DEFLECTION. SEE TABLE FOR VALUES.
- T-BOLTS PER AWWA C111. STAINLESS STEEL FASTENERS AVAILABLE UPON REQUEST.

<p>PROPRIETARY NOTICE</p> <p>THIS DRAWING CONTAINS CONFIDENTIAL PROPRIETARY INFORMATION AND IS THE PROPERTY OF ROMAC IND., INC. IT IS TO BE USED ONLY FOR THE PURPOSE FOR WHICH IT WAS SUBMITTED AND SHALL NOT HAVE IT'S INFORMATION DISCLOSED OR REPRODUCED IN WHOLE OR IN PART FOR ANY PURPOSE WITHOUT PRIOR WRITTEN PERMISSION OF ROMAC IND., INC.</p>	<p>UNLESS OTHERWISE SPECIFIED</p> <p>DIMENSIONS ARE IN INCHES</p> <p>TOLERANCES ARE ON: 1 PL DECIMALS ± .060 2 PL DECIMALS ± .030 3 PL DECIMALS ± .010 ANGLES ± 1° FRACTIONS ± 1/64</p>	<p>SIGNATURES</p> <p>DRAWN</p> <p>CHECKED</p> <p>APPROVAL ORGANIZATIONS ENGINEERING</p>		<p>ROMAC INDUSTRIES INC., BOTHELL, WA</p> <p>TITLE DISMANTLING JOINT DJ405 3" - 24"</p>	<p>DWG. NO. B2128-A</p>	<p>SIZE A</p>	<p>REV. NO. 3</p>	<p>SCALE NTS</p>	<p>SHEET 1 OF 1</p>
---	--	---	--	---	------------------------------------	--------------------------	------------------------------	-----------------------------	--------------------------------