

PART NO.	QTY.	NAME	DESCRIPTION
1	2	CASING	AVAILABLE FLANGED OR MJ END. ASTM A536 DUCTILE IRON. FLANGE DRILLING PER ANSI B16.1 CLS 125/ANSI B16.5 CLS 150. MJ END PER AWWA C111 AND AWWA C153
2	2	BALL	ASTM A536 DUCTILE IRON
3	2	CASING COVER	ETHYLENE PROPYLENE DIENE METHYLENE (EPDM) RUBBER
4	2	CASING GASKET	ETHYLENE PROPYLENE DIENE METHYLENE (EPDM) RUBBER
5	2	LOCKRING	TYPE 400 SERIES STAINLESS STEEL
6	2	BALL GASKET	ETHYLENE PROPYLENE DIENE METHYLENE (EPDM) RUBBER
7	1	SLEEVE	ASTM A536 DUCTILE IRON. GROOVED EACH END TO ACCEPT LOCK RING

NOM SIZE	OFFSET	A	B	C	D	E	FLANGE X FLANGE L1	MJ X FLANGE L1	MJ X MJ L1	L2	TOTAL EXPANSION	ANGLE
3"	4	6.8	6.2	8.2	5.7	11.9	24.7	24.1	23.5	11.2	4.00	20.0°
	8						35.7	35.1	34.5	22.2		
	12						46.7	46.1	45.5	33.2		
	16						57.7	57.1	56.5	44.2		
4"	4	7.0	6.4	9.4	6.3	13.2	26.7	26.1	25.5	12.6	4.00	19.0°
	8						37.7	37.1	36.5	23.6		
	12						49.7	49.1	48.5	35.6		
	16						60.7	60.1	59.5	46.6		
6"	4	7.9	7.5	11.9	7.4	15.6	28.9	28.6	28.2	13.2	6.26	18.0°
	8						40.9	40.6	40.2	25.2		
	12						52.9	52.6	52.2	37.2		
	16						65.9	65.6	65.2	50.2		
8"	4	8.8	8.0	14.4	8.7	18.1	31.1	30.3	29.5	13.4	6.26	17.0°
	8						44.1	43.3	42.5	26.4		
	12						57.1	56.3	55.5	39.4		
	16						70.1	69.3	68.5	52.4		
10"	4	9.3	8.6	16.9	10.1	20.7	33.6	32.9	32.2	14.9	6.26	16.0°
	8						46.6	45.9	45.2	27.9		
	12						60.6	59.9	59.2	41.9		
	16						74.6	73.9	73.2	55.9		
12"	4	10.0	9.2	19.4	11.3	23.7	35.5	34.7	33.9	15.4	7.88	15.0°
	8						50.5	49.7	48.9	30.4		
	12						65.5	64.7	63.9	45.4		
	16						80.5	79.7	78.9	60.4		
14"	4	10.9	11.0	21.7	12.7	26.2	42.9	43.0	43.1	21.0	7.88	15.0°
	8						55.9	56.0	56.1	34.0		
	12						69.9	70.0	70.1	48.0		
	16						84.9	85.0	85.1	63.0		
16"	4	11.7	11.7	24.1	14.0	28.6	46.7	46.5	46.4	23.0	9.44	15.0°
	8						57.7	57.5	57.4	34.0		
	12						72.7	72.5	72.4	49.0		
	16						87.7	87.5	87.4	64.0		
18"	4	12.5	12.3	26.3	15.1	30.9	49.0	48.7	48.5	23.9	9.44	15.0°
	8						60.0	59.7	59.5	34.9		
	12						74.0	73.7	73.4	48.9		
	16						89.0	88.7	88.5	63.9		
20"	4	13.7	13.2	29.2	16.9	34.3	52.9	52.4	51.9	25.5	11.82	15.0°
	8						61.9	61.4	60.9	34.5		
	12						77.9	77.4	76.9	50.5		
	16						92.9	92.4	91.9	65.5		
24"	4	14.9	14.5	34.7	19.7	39.4	56.2	55.8	55.4	26.5	11.82	15.0°
	8						64.2	63.8	63.4	34.5		
	12						80.2	79.8	79.4	50.5		
	16						95.2	94.8	94.4	65.5		
20	110.2	109.8	109.4	80.5								

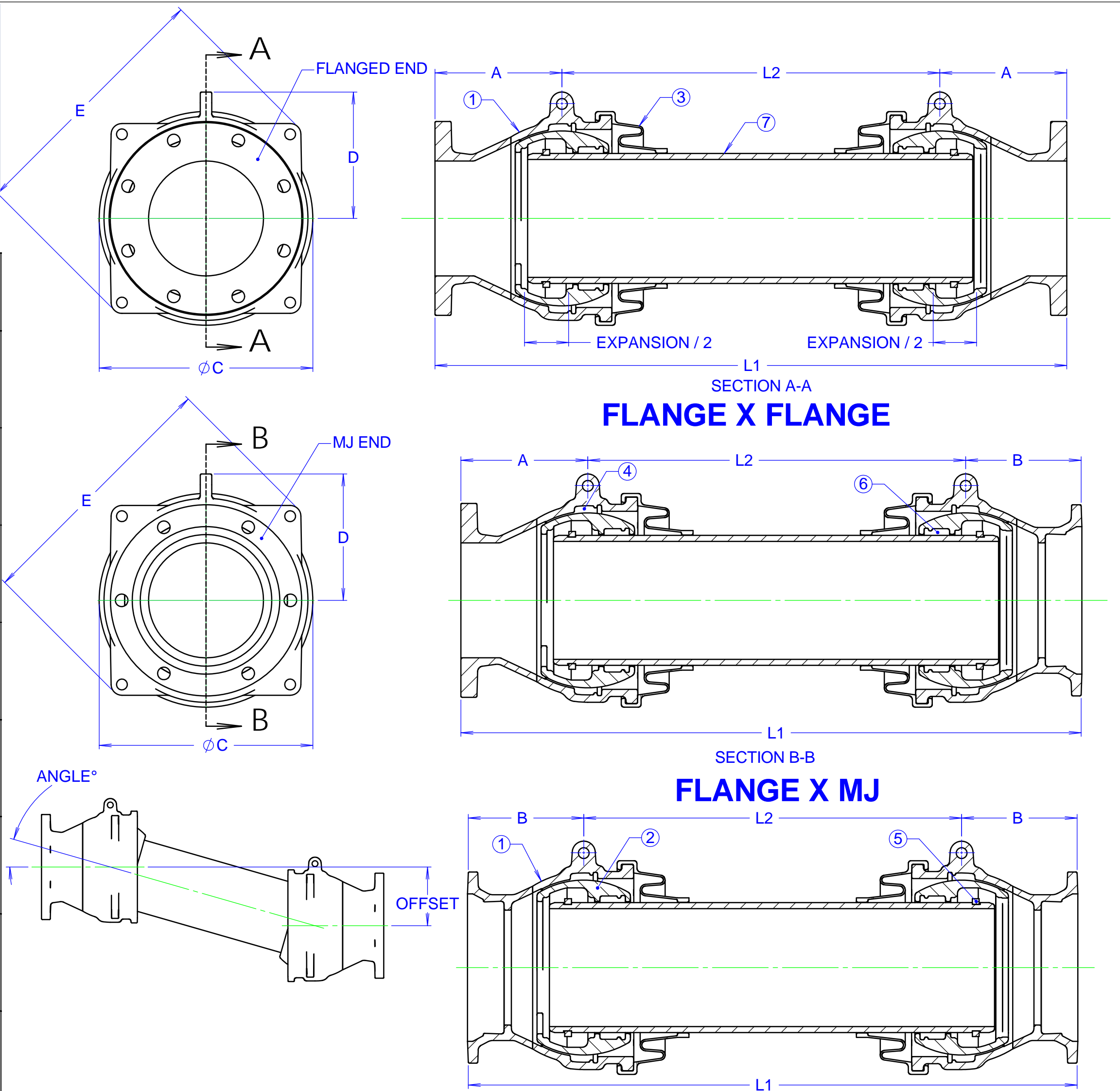

NOTE:
 1. COATING: LINED AND COATED WITH FUSION BONDED EPOXY, APPLIED AND TESTED IN ACCORDANCE WITH AWWA C213.
 2. END THRUST MUST BE ACCOMMODATED IN DESIGN OF PIPING SYSTEMS. THE THRUST AT THE FJ-RESTRAINT WILL BE IN PROPORTION TO THE PRESSURE APPLIED IN THE SYSTEM. SEE THE TABLE BELOW FOR AREA AND TYPICAL THRUST LOADS.
 3. L1 EQUALS MIDPOINT OF EXPANSION.

SIZE	CROSS-SECT. DIA.	AREA (in ²)	END THRUST (lbs.)		
			50 psi	100 psi	150 psi
3"	Ø3.96	12.3	616	1,232	1,847
4"	Ø4.80	18.1	905	1,810	2,714
6"	Ø6.90	37.4	1,870	3,739	5,609
8"	Ø9.05	64.3	3,216	6,433	9,649
10"	Ø11.10	96.8	4,838	9,677	14,515
12"	Ø13.20	136.8	6,842	13,685	20,527
14"	Ø15.30	183.9	9,193	18,385	27,578
16"	Ø17.40	237.8	11,889	23,779	35,668
18"	Ø19.50	298.6	14,932	29,865	44,797
20"	Ø21.60	366.4	18,322	36,644	54,965
24"	Ø25.80	522.8	26,140	52,279	78,419

REV.	DESCRIPTION	DATE	APPROVED
0	INITIAL RELEASE	12/12/2002	S LALONDE
1	ADDED NOTE 2 AND THRUST TABLE	12/28/2004	DH EATON
2	REVISED L1 FOR 16" FL X FL & FL X MJ	11/30/2006	DH EATON
3	REVISED FOR EXPANSION NOTATION	9/15/2008	P ZIMPELMAN
4	UPDATED TEMPLATE & DWG TITLE, CHANGED TO TOTAL EXPANSION	5/2/2011	N. THOGERSEN

PROPRIETARY NOTICE: THIS DRAWING CONTAINS CONFIDENTIAL PROPRIETARY INFORMATION AND IS THE PROPERTY OF ROMAC IND., INC. IT IS TO BE USED ONLY FOR THE PURPOSE FOR WHICH IT WAS SUBMITTED AND SHALL NOT HAVE ITS INFORMATION DISCLOSED OR REPRODUCED IN WHOLE OR IN PART FOR ANY PURPOSE WITHOUT PRIOR WRITTEN PERMISSION OF ROMAC IND., INC.

UNLESS OTHERWISE SPECIFIED: DIMENSIONS ARE IN INCHES. TOLERANCES ARE ON: 1 PL DECIMALS ±, 2 PL DECIMALS ±, 3 PL DECIMALS ±, FRACTIONS ±.

SIGNATURES: DRAWN, CHECKED, APPROVAL ORGANIZATIONS.

ROMAC INDUSTRIES INC., BOTHELL, WA. TITLE: FJ-Restraint, DOUBLE BALL, 3" - 24".

DWG. NO: B2121-C, SIZE: C, REV. NO: 4, SCALE: NTS, SHEET: 1 OF 1.