

REVISIONS			
REV.	DESCRIPTION	DATE	APPROVED
0	INITIAL RELEASE	10/7/09	PNN

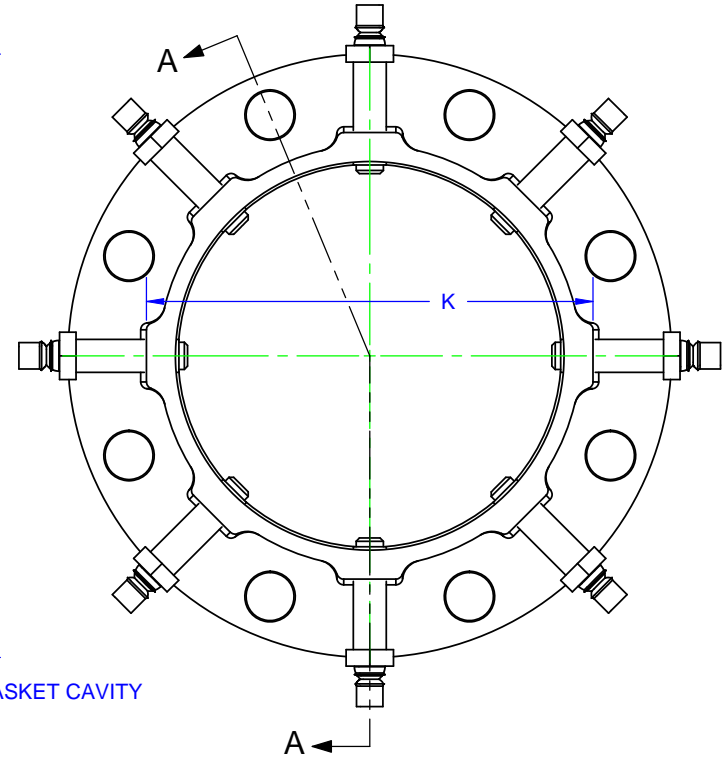
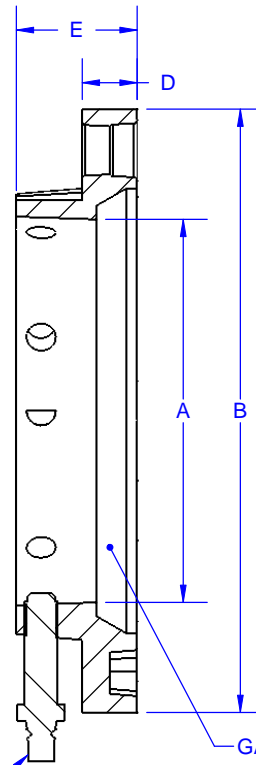
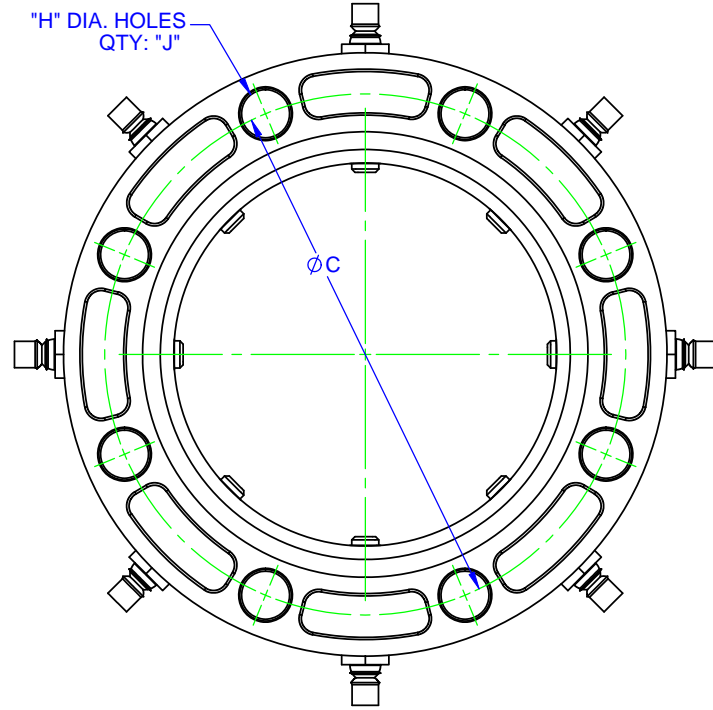

5/8"-11 X 2" UNC SET SCREW,
4140 STEEL ALLOY WITH 7/16",
12 PT HEAD,
QTY: "F"

SECTION A-A

NOTES:

1. FLANGE IN ACCORDANCE WITH ANSI CLASS 150 FLANGE DRILLING.
2. COATING: SHOP COAT APPLIED TO THE CASTING FOR CORROSION PROTECTION IN TRANSIT. NSF-61 APPROVED EPOXY ALSO AVAILABLE ON REQUEST.
3. GASKET: SBR COMPOUNDED FOR WATER AND SEWER SERVICE IN ACCORDANCE WITH ASTM D 2000 MBA 710. NBR AND EPDM ALSO AVAILABLE ON REQUEST.
4. CAN BE USED ON DUCTILE IRON AND STEEL PIPE. NOT FOR USE ON PVC/PLASTIC PIPE OR PLAIN END MECHANICAL JOINT FITTINGS. NOT RECOMMENDED FOR USE ON CLASS 50 DUCTILE IRON PIPE.
5. ALL MATERIAL DUCTILE IRON PER ASTM A536, GRADE 65-45-12 UNLESS OTHERWISE SPECIFIED.

SIZE	I.D.	O.D.	B.C.	FLANGE		# OF SET SCREWS	BOLT HOLES			O.D. TO	WORKING PRESSURE	MAX JOINT DEFLECTION	APPROX WEIGHT (LBS.)
	A	B	C	D	E		H	J	K	PAD			
4"	4.90	9.00	7.50	1.02	2.03	4	0.750	8	6.25	300	3°	11#	
6"	7.00	11.00	9.50	1.00	2.22	8	0.875	8	8.31	300	2°	16#	
8"	9.12	13.00	11.75	1.15	2.23	8	0.875	8	10.52	300	2°	19#	
10"	11.18	16.00	14.25	1.20	2.45	12	1.00	12	12.45	250	2°	31#	
12"	13.30	19.00	17.00	1.25	2.50	12	1.00	12	15.00	175	1.5°	43#	

<p>PROPRIETARY NOTICE</p> <p>THIS DRAWING CONTAINS CONFIDENTIAL PROPRIETARY INFORMATION AND IS THE PROPERTY OF ROMAC IND., INC. IT IS TO BE USED ONLY FOR THE PURPOSE FOR WHICH IT WAS SUBMITTED AND SHALL NOT HAVE ITS INFORMATION DISCLOSED OR REPRODUCED IN WHOLE OR IN PART FOR ANY PURPOSE WITHOUT PRIOR WRITTEN PERMISSION OF ROMAC IND., INC.</p>	<p>UNLESS OTHERWISE SPECIFIED</p> <p>DIMENSIONS ARE IN INCHES</p> <p>TOLERANCES ARE ON: 1 PL DECIMALS ± .060 2 PL DECIMALS ± .030 3 PL DECIMALS ± .010 ANGLES ± 1° FRACTIONS ± 1/64</p>	<p>SIGNATURES</p> <p>DRAWN</p> <p>CHECKED</p> <p>APPROVAL ORGANIZATIONS ENGINEERING</p>		<p>ROMAC INDUSTRIES INC., BOTHELL, WA</p>			
	<p>TITLE</p> <p>4" - 12" FIELD FLANGE</p>						
	<p>DWG. NO.</p> <p>B3290-A</p>	<p>SIZE</p> <p>A</p>		<p>REV. NO.</p> <p>0</p>	<p>SCALE</p> <p>NTS</p>	<p>SHEET</p> <p>1 OF 1</p>	