

B3359-A

REVISIONS			
REV.	DESCRIPTION	DATE	APPROVED
0	INITIAL RELEASE	3/15/10	SAM HILL

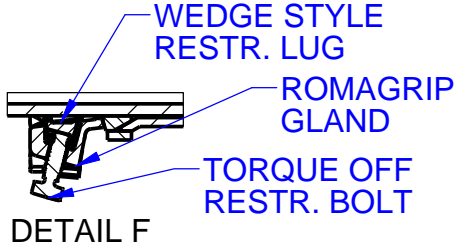
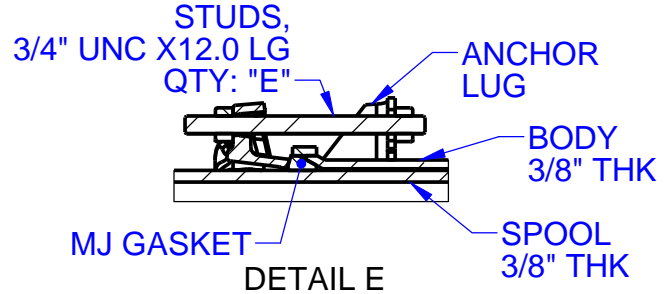
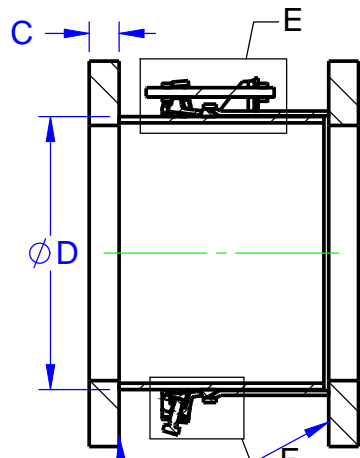
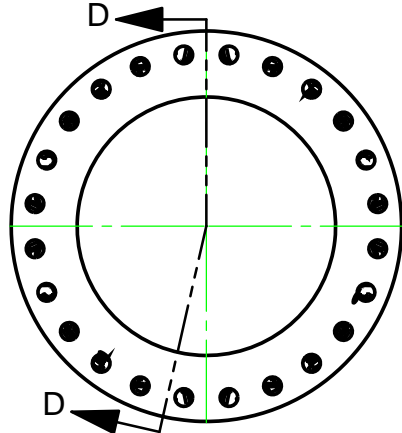
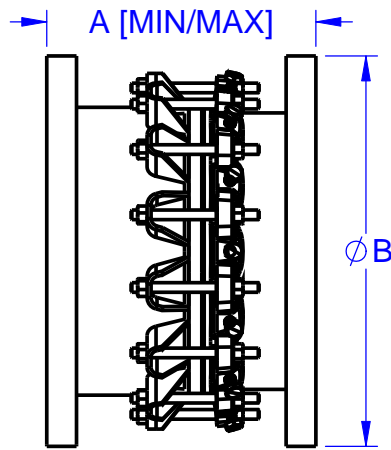

AWWA CLS F FLANGE

SECTION D-D

NOTES:

1. COATING PER CUSTOMER ORDER
2. FASTENERS: STEEL PER ASTM A193 GR B7, STAINLESS STEEL TYPE 304 GRADE B8, TYPE 316 GR B8M
3. MATERIAL: DUCTILE IRON AND A36 STEEL.
4. SOME INITIAL AXIAL MOVEMENT MAY OCCUR AS LUG SEATS ON PIPE. APPROX. 0.25" OF MOVEMENT CAN BE EXPECTED IN SIZES UNDER 16". FOR LARGER SIZES, MOVEMENT OF APPROX. 0.4" MAY BE SEEN.

NOM SIZE	DIMENSIONS						MAX DEFL. (DEG.)	STUDS QTY "E"	PRESSURE (PSIG)	
	LENGTH "A"			FLG OD "B"	FLG THK "C"	SPOOL OD "D"			WKG	TEST
	NOM	MIN	MAX							
12	25.25	23.75	26.75	20.50	1.63	13.2	3	8	300	375
14	26.75	25.25	28.25	23.00	1.94	15.3	2	10	300	375
16	27.50	26.00	29.00	25.50	2.14	17.4	2	12	300	375
18	28.00	26.50	29.50	28.00	2.25	19.5	1.5	12	250	375
20	28.50	27.00	30.00	30.50	2.33	21.6	1.5	14	250	375
24	30.25	28.75	31.75	36.00	2.69	25.8	1.5	16	250	375

PROPRIETARY NOTICE
THIS DRAWING CONTAINS CONFIDENTIAL PROPRIETARY INFORMATION AND IS THE PROPERTY OF ROMAC IND., INC. IT IS TO BE USED ONLY FOR THE PURPOSE FOR WHICH IT WAS SUBMITTED AND SHALL NOT HAVE ITS INFORMATION DISCLOSED OR REPRODUCED IN WHOLE OR IN PART FOR ANY PURPOSE WITHOUT PRIOR WRITTEN PERMISSION OF ROMAC IND., INC.

UNLESS OTHERWISE SPECIFIED
DIMENSIONS ARE IN INCHES
TOLERANCES ARE ON:
1 PL DECIMALS ± .060
2 PL DECIMALS ± .030
3 PL DECIMALS ± .010
ANGLES ± 1°
FRACTIONS ± 1/64

SIGNATURES
DRAWN
CHECKED
APPROVAL ORGANIZATIONS
ENGINEERING

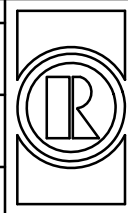

ROMAC INDUSTRIES INC.,
BOTHELL, WA
TITLE
DJ405 12"-24"
CLS F FLANGES
DWG. NO. B3359-A SIZE A REV. NO. 0 SCALE NTS SHEET 1 OF 1