

B3722-A

REVISIONS			
REV	DESCRIPTION	DATE	APPROVED
0	INITIAL RELEASE	6/21/10	SH

DIMENSIONS						
NOM. SIZE	PIPE OD RANGE	K	L	R	H	W
2"	2.38 - 2.50	2	4.88	1.25	1.35	3.31
3"	3.50	2	5.94	1.75	1.35	3.31
4"	4.50 - 4.80	2	7.00	2.40	1.50	4.00
6"	6.63 - 6.90	2	8.81	3.45	1.50	4.00
8"	8.63 - 9.05	3	11.13	4.53	1.50	4.00
10"	10.75 - 11.10	3	13.06	5.55	1.50	4.00
12"	12.75 - 13.20	4	16.19	6.60	1.50	4.00

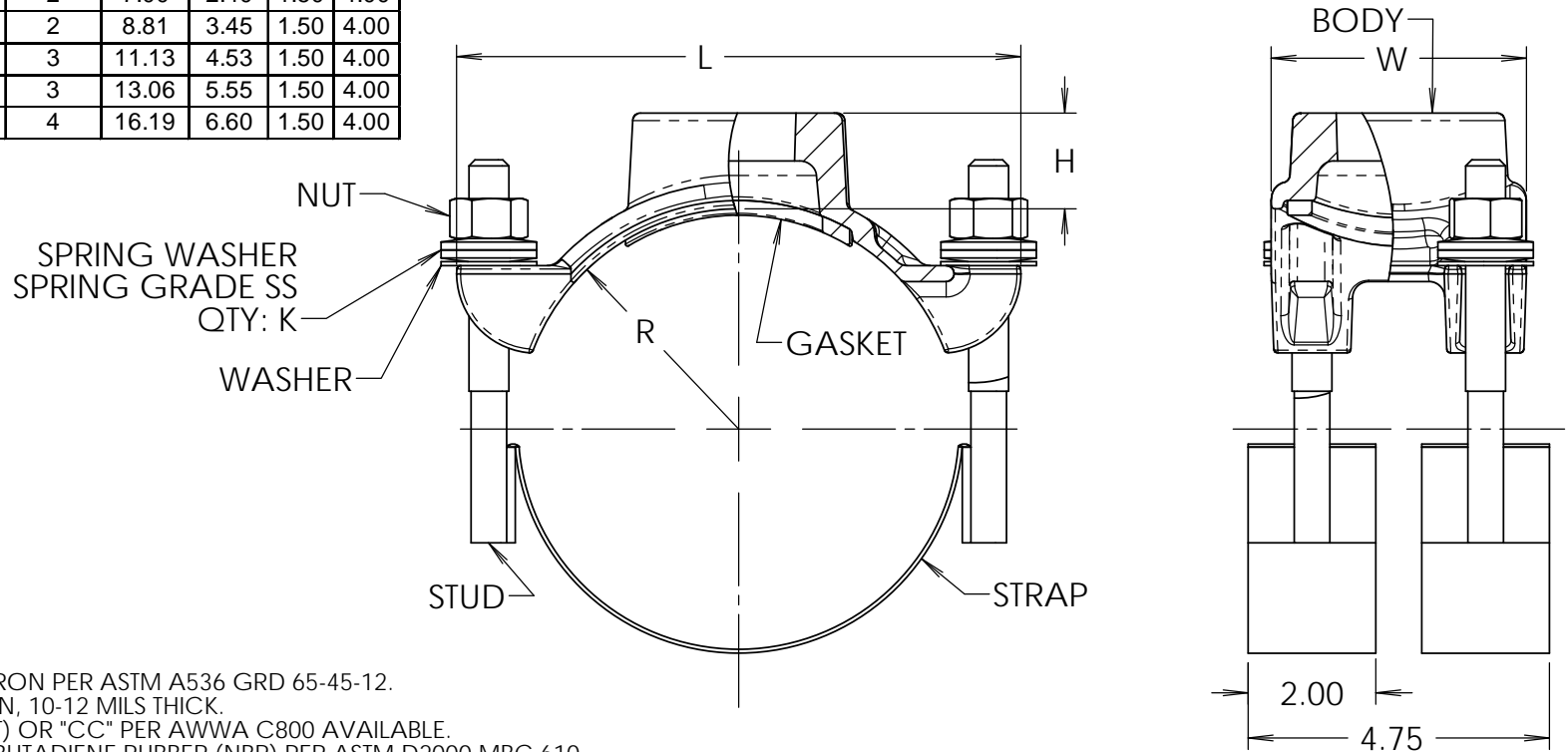

NOTE:

1. BODY: DUCTILE IRON PER ASTM A536 GRD 65-45-12.
2. COATING: NYLON, 10-12 MILS THICK.
3. THREAD: "IP" (NPT) OR "CC" PER AWWA C800 AVAILABLE.
4. GASKET: NITRILE BUTADIENE RUBBER (NBR) PER ASTM D2000 MBC 610.
5. STRAP, STUD, AND NUT: TYPE 304 STAINLESS STEEL:
 - WELDING: GMAW AND GTAW. CHEMICALLY CLEANED AND PASSIVATED.
 - 1-1/2" THROUGH 3" SIZES, 1/2"-NC ROLL THREAD, WITH HEAVY HEX NUTS AND 1/2" FLAT WASHER.
 - 4" AND LARGER SIZES, 5/8"-NC ROLL THREAD, WITH HEAVY HEX NUT AND 5/8" FLAT WASHER.
6. SADDLES NOT TO BE USED ON HDPE PIPE WITH SDR GREATER THAN 26

PROPRIETARY NOTICE	UNLESS OTHERWISE SPECIFIED	SIGNATURES	ROMAC INDUSTRIES INC., BOTHELL, WA			
THIS DRAWING CONTAINS CONFIDENTIAL PROPRIETARY INFORMATION AND IS THE PROPERTY OF ROMAC IND., INC. IT IS TO BE USED ONLY FOR THE PURPOSE FOR WHICH IS WAS SUBMITTED AND SHALL NOT HAVE IT'S INFORMATION DISCLOSED OR REPRODUCED IN WHOLE OR IN PART FOR ANY PURPOSE WITHOUT PRIOR WRITTEN PERMISSION OF ROMAC IND., INC.	DIMENSIONS ARE IN INCHES TOLERANCES ARE ON: 1 PL DECIMALS ± .060 2 PL DECIMALS ± .030 3 PL DECIMALS ± .010 ANGLES ± 1° FRACTIONS ± 1/64	DRAWN	TITLE 202N-H SERVICE SADDLES FOR HDPE			
		CHECKED				
		APPROVAL ORGANIZATIONS ENGINEERING	DWG. NO. B3722-A	SIZE A	REV. NO. 0	SCALE NTS