

SIZE	DIMENSIONS						
	HOT	COLD	ØA	ØB	C	D	ØE
3	25.13	35.13	7.69	3.50	SCH 10	4	7.50
4	25.13	35.13	8.69	4.50	SCH 10	4	9.00
5	25.25	35.25	9.75	5.56	SCH 10	4	10.00
6	25.44	35.44	10.81	6.63	SCH 10	5	11.00
8	25.44	35.44	12.81	8.63	SCH 40	6	13.50
10	25.56	35.56	14.94	10.75	SCH 40	7	16.00
12	25.94	35.94	16.94	12.75	SCH 40	8	19.00

REVISIONS			
REV	DESCRIPTION	DATE	APPROVED

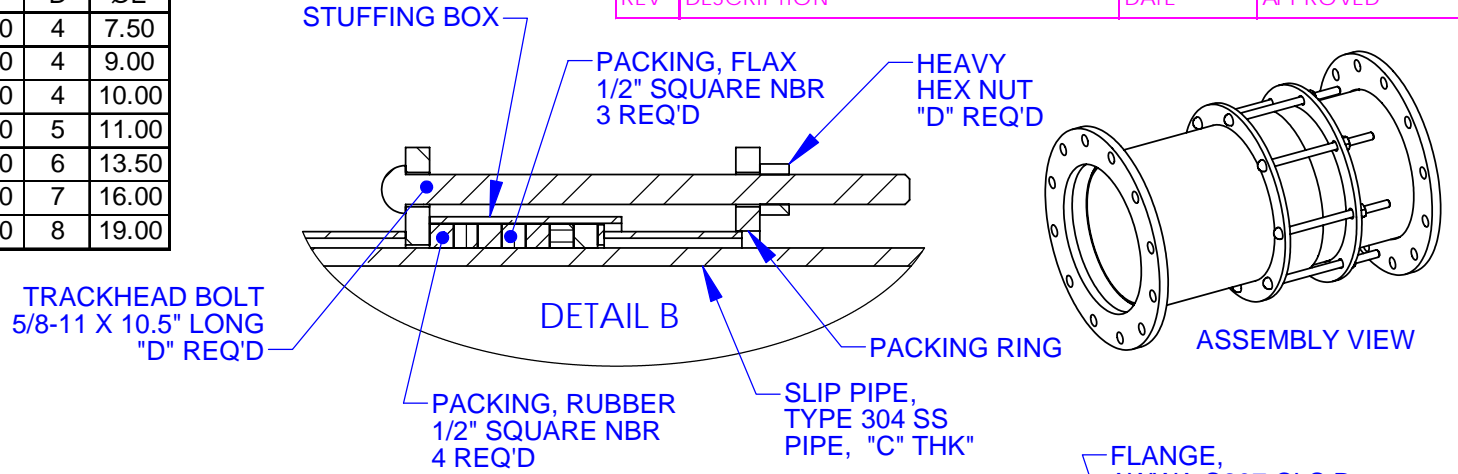

TECHNICAL DATA:

- EXPANSION JOINT TYPE: SINGLE SIDED.FLANGED ENDS PROVIDED FOR BOLTING INTO PLACE.
- MAXIMUM ALLOWABLE TRAVEL: 10.00"
- MAX. PRESSURE RATING: 175 PSIG WORKING, 263 PSIG TEST.
- MATERIAL OF CONSTRUCTION: CUSTOMER SPECIFIED ASTM A36 STEEL OR ASTM A240 TYPE 304 STAINLESS STEEL.
- COATING:
 - STEEL : SHOPCOAT PAINT OR FUSION BONDED EPOXY..
 - STAINLESS STEEL: CHEMICALLY PASSIVATED FOR MAXIMUM CORROSION RESISTANCE.
- FASTENERS: CUSTOMER SPECIFIED HSLA , TYPE 304 SS, OR TYPE 316 SS.
- INSTALLATION INTRUCTIONS WILL BE PROVIDED FOR FIELD ASSEMBLY.
- ROMAC EJ401 IS DESIGNED FOR AXIAL PIPE MOVEMENT ONLY.
- MEETS STANDARD AWWA C221

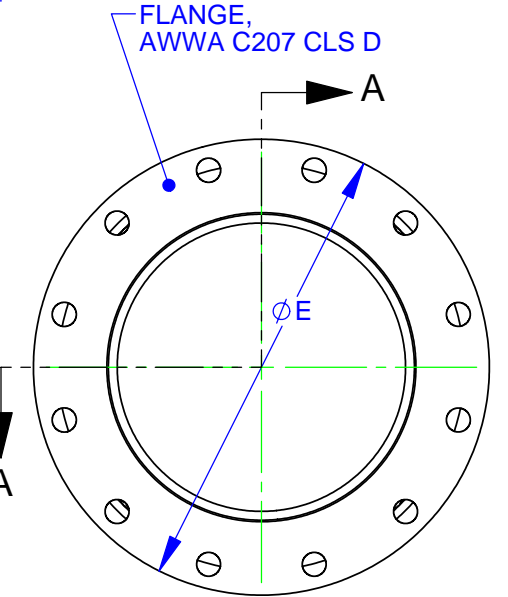
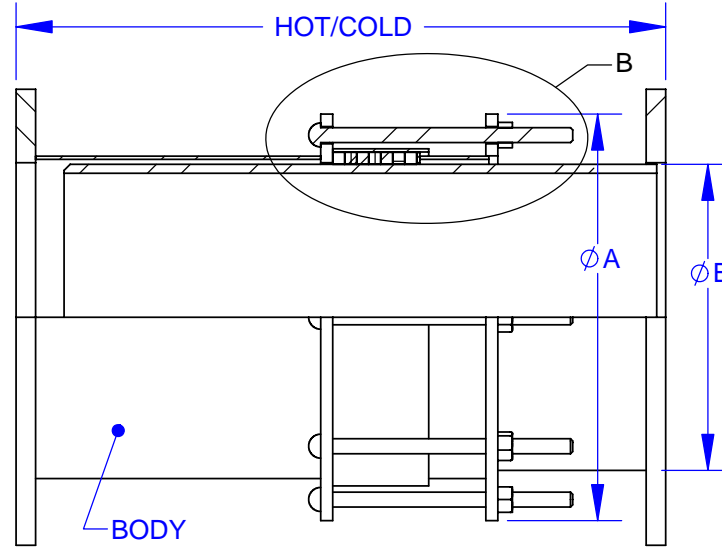

SECTION A-A

UNLESS OTHERWISE SPECIFIED DIMENSIONS ARE IN INCHES TOLERANCES ARE ON: 2 PL DECIMALS +/- .05 3 PL DECIMALS +/- ANGLES +/- FRACTIONS +/-	SIGNATURES	DATE		ROMAC IND. INC., SEATTLE, WA	
	CHECKED	TITLE EXPANSION JOINT EJ401 3" - 12", 10.00 TRAVEL FLANGED ENDS			
	SIZE A	DWG. NO. B2634-A	REV. NO. -	SCALE NTS	SHEET 1 OF 1

THIS DRAWING CONTAINS CONFIDENTIAL PROPRIETARY INFORMATION AND IS THE PROPERTY OF ROMAC IND., INC. IT'S TO BE USED ONLY FOR THE PURPOSE FOR WHICH IT'S SUBMITTED AND SHALL NOT HAVE ITS INFORMATION DISCLOSED OR REPRODUCED IN WHOLE OR IN PART FOR ANY PURPOSE WITHOUT PRIOR WRITTEN PERMISSION OF ROMAC IND., INC.