

# **FJ** **RESTRAINT**™

**FLEXIBLE EXPANSION JOINT**



The Romac FJ Restraint is a flexible, ductile iron expansion joint, developed to accommodate pipeline forces that could result in damage or loss of service.

The FJ Restraint compensates for expansion, contraction, rotation, bending and settlement of your pipeline, all at the same time.

FJ Restraints are available with flanged or Mechanical Joint style ends.

The FJ Restraint can be used at working pressures up to 350 psi.

Sizes range from 3 inches to 24 inches.



# OVERVIEW

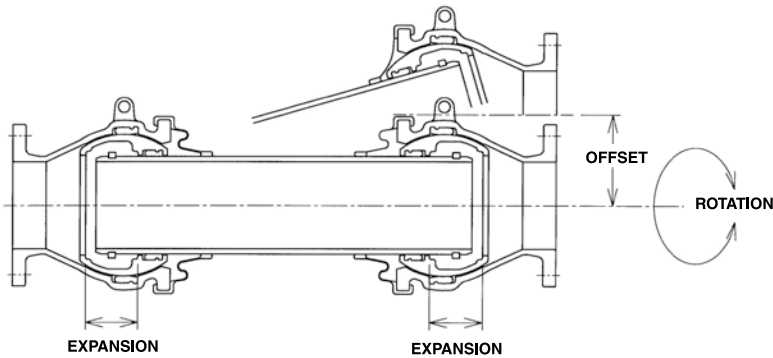

## BOLTLESS DESIGN

The FJ Restraint requires no threaded fasteners for assembly. The advanced design eliminates the need for flanged assembly connections in the casing. The resulting one-piece casing construction is an essential element that achieves restraint capabilities of 8.4d<sup>1</sup> tons of force for all sizes. By eliminating unnecessary components, the compact design allows a lightweight assembly for ease of installation.

## OFFSET

Each FJ Restraint ball end provides a bending angle of up to  $\pm 15^\circ$  to  $\pm 20^\circ$  (depending on size). This corresponds to a total bending angle of  $\pm 30^\circ$  to  $\pm 40^\circ$ . By varying the length of the sleeve, the FJ will also accommodate lateral offset of 4 to 20 inches. When special conditions demand, a FJ of 3 to 12 inches in size can accommodate an additional bending angle. Please contact Romac Industries, Inc. for assistance when your application requires special consideration.

## EXPANSION

Since all of the FJ Restraint's expansion occurs inside the ball joint, there is no need for expansion type sleeves. The centrifrically cast ductile iron sleeve is one piece, which minimizes any turbidity.

## TORSION

The design of the FJ Restraint will allow rotation or torsion of the pipeline components. This freedom of movement prevents damage to flanges, valves and other structures associated with the pipeline.

## EASY TO INSTALL

Romac FJ Restraints arrive from the factory with tie-rods in place to prevent deflection and changes to the end-to-end dimension during transportation and installation. Tie-rods are then removed once installation is complete.

NOM. SIZE (inches)	DEFLECTION ANGLE (degrees)	OFFSET (inches)	EXPANSION CONTRACTION (inches)	MAX. THRUST RESTRAINT LOAD (lbs.)*
3	20.0	4.0 - 20.0	4.00	50,400
4	19.0	4.0 - 20.0	4.00	67,200
6	18.0	4.0 - 20.0	6.25	100,800
8	17.0	4.0 - 20.0	6.25	134,400
10	16.0	4.0 - 20.0	6.25	168,000
12	15.0	4.0 - 20.0	7.88	201,600
14	15.0	4.0 - 20.0	7.88	235,200
16	15.0	4.0 - 20.0	9.44	268,800
18	15.0	4.0 - 20.0	9.44	302,400
20	15.0	4.0 - 20.0	11.81	336,000
24	15.0	4.0 - 20.0	11.81	403,200

\*Maximum thrust equals 16,800d lbs., where "d" = nominal size.

1. Where "d" is in inches.

No.	Name of Parts	Material
1	Casing	ASTM A536 <sup>1</sup>
2	Ball	ASTM A536
3	Sleeve	ASTM A536
4	Lock Ring	Type 410 SS
5	Ring Gasket, Casing	EPDM <sup>2</sup>
6	Ring Gasket, Ball	EPDM <sup>2</sup>
7	Casing Cover	EPDM <sup>2</sup>

1. ASTM A536, Ductile Iron, Grade 65-45-12  
 2. EPDM: Ethylene Propylene Diene Rubber

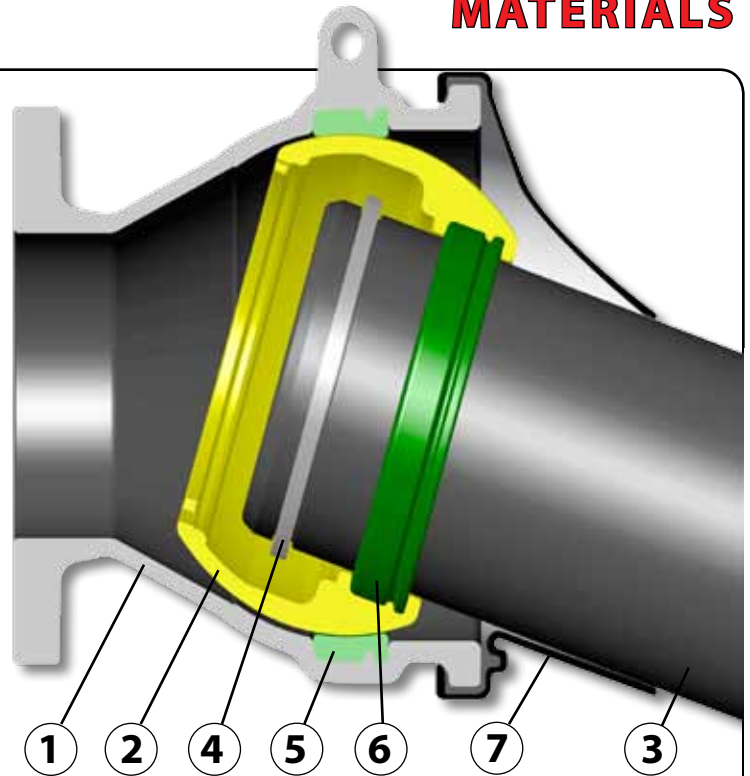

## MATERIAL SPECIFICATIONS

**Castings:** The casing, ball and sleeve are cast of ductile (nodular) iron, meeting or exceeding ASTM A 536, Grade 65-45-12.

**Flange:** Compatible with ANSI Class 125 and 150 bolt circles.

**Lock Ring:** Series 400 stainless steel. Limits expansion and contraction of FlexiJoint up to maximum working pressure.

**Ring Gaskets:** Ring gaskets are made of dual Ethylene Propylene Diene Methylene (EPDM) compounded for water and sewer service.

**Casing Cover:** Covers are made of Ethylene Propylene Diene Methylene (EPDM) compounded for water and sewer service.

**Coatings:** The entire fitting is lined and coated with fusion bonded epoxy, applied and tested in accordance with AWWA C213.

**Protective Sleeve:** Polyethylene sleeve, 8 mils thick to cover entire FJ assembly after installation. Provided with flexible rubber bands to secure to pipe ends and FJ.

**Pressure:** When properly installed the FJ can be used at working pressures up to 350 psi.



3 inch through 12 inch.

# FJ RESTRAINT DIMENSIONS

FJ Restraints are available in double-ball and single-ball joint configurations.

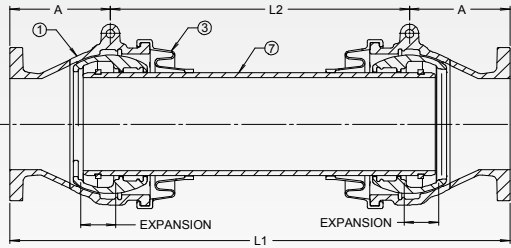
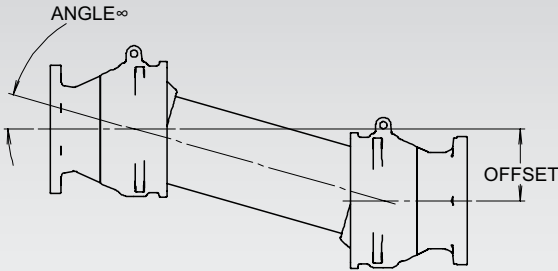

SECTION A-A  
**FLANGE X FLANGE**

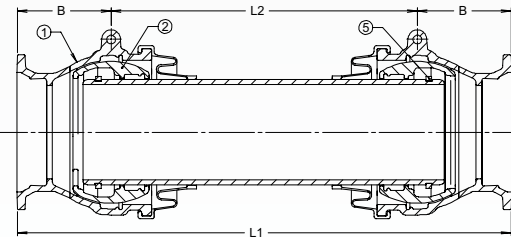

SECTION C-C  
**MJ X MJ**

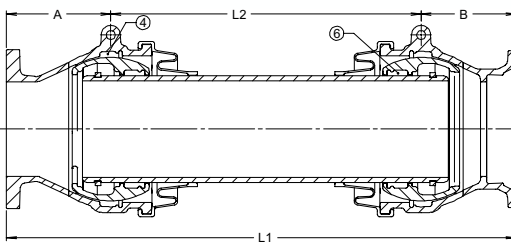

SECTION B-B  
**FLANGE X MJ**

NOM SIZE	OFFSET	A	B	C	D	E	FLANGE X FLANGE	MJ X FLANGE	MJ X MJ	EXPANSION	ANGLE	
							L1	L1	L1			L2
3"	4	6.8	6.2	8.2	5.7	11.9	24.7	24.1	23.5	±2.00	20.0°	
	8						35.7	35.1	34.5			22.2
	12						46.7	46.1	45.5			33.2
	16						57.7	57.1	56.5			44.2
	20						68.7	68.1	67.5			55.2
4"	4	7.0	6.4	9.4	6.3	13.2	26.7	26.1	25.5	±2.00	19.0°	
	8						37.7	37.1	36.5			23.6
	12						49.7	49.1	48.5			35.6
	16						60.7	60.1	59.5			46.6
	20						72.7	72.1	71.5			58.6
6"	4	7.9	7.5	11.9	7.4	15.6	28.9	28.6	28.2	±3.13	18.0°	
	8						40.9	40.6	40.2			25.2
	12						52.9	52.6	52.2			37.2
	16						65.9	65.6	65.2			50.2
	20						77.9	77.6	77.2			62.2
8"	4	8.8	8.0	14.4	8.7	18.1	31.1	30.3	29.5	±3.13	17.0°	
	8						44.1	43.3	42.5			26.4
	12						57.1	56.3	55.5			39.4
	16						70.1	69.3	68.5			52.4
	20						83.1	82.3	81.5			65.4
10"	4	9.3	8.6	16.9	10.1	20.7	33.6	32.9	32.2	±3.13	16.0°	
	8						46.6	45.9	45.2			27.9
	12						60.6	59.9	59.2			41.9
	16						74.6	73.9	73.2			55.9
	20						88.6	87.9	87.2			69.9
12"	4	10.0	9.2	19.4	11.3	23.7	35.5	34.7	33.9	±3.94	15.0°	
	8						50.5	49.7	48.9			30.4
	12						65.5	64.7	63.9			45.4
	16						80.5	79.7	78.9			60.4
	20						95.5	94.7	93.9			75.4
14"	4	10.9	11.0	21.7	12.7	26.2	42.9	43.0	43.1	±3.94	15.0°	
	8						55.9	56.0	56.1			34.0
	12						69.9	70.0	70.1			48.0
	16						84.9	85.0	85.1			63.0
	20						99.9	100.0	100.1			78.0
16"	4	11.7	11.7	24.1	14.0	28.6	46.7	46.5	46.4	±4.72	15.0°	
	8						57.7	57.5	57.4			34.0
	12						72.7	72.5	72.4			49.0
	16						87.7	87.5	87.4			64.0
	20						102.7	102.5	102.4			79.0
18"	4	12.5	12.3	26.3	15.1	30.9	49.0	48.7	48.5	±4.72	15.0°	
	8						60.0	59.7	59.5			34.9
	12						74.0	73.7	73.4			48.9
	16						89.0	88.7	88.5			63.9
	20						104.0	103.7	103.5			78.9
20"	4	13.7	13.2	29.2	16.9	34.3	52.9	52.4	51.9	±5.91	15.0°	
	8						61.9	61.4	60.9			34.5
	12						77.9	77.4	76.9			50.5
	16						92.9	92.4	91.9			65.5
	20						107.9	107.4	106.9			80.5
24"	4	14.9	14.5	34.7	19.7	39.4	56.2	55.8	55.4	±5.91	15.0°	
	8						64.2	63.8	63.4			34.5
	12						80.2	79.8	79.4			50.5
	16						95.2	94.8	94.4			65.5
	20						110.2	109.8	109.4			80.5

Dimension "L1" equals midpoint of expansion.

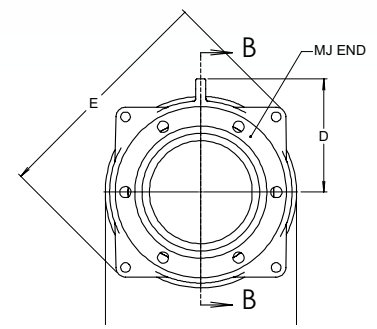
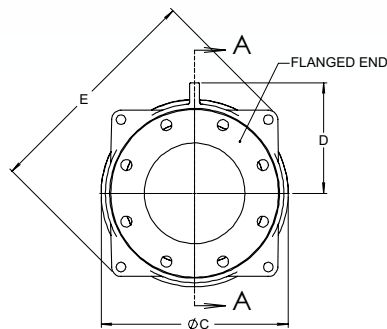

# APPLICATION EXAMPLES

**AQUEDUCTS**

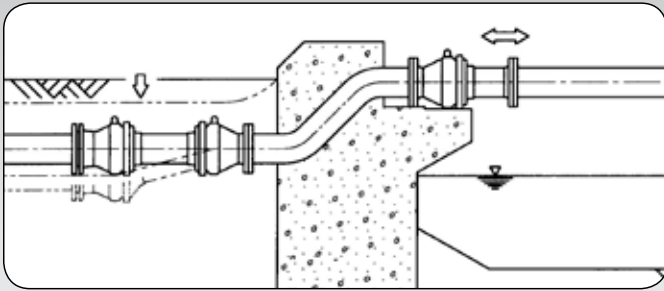

**UNDER A RIVER CROSSING**

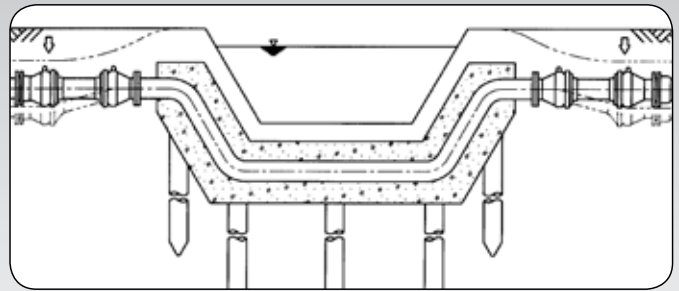

**LEADING INTO AND OUT OF A TANK.**

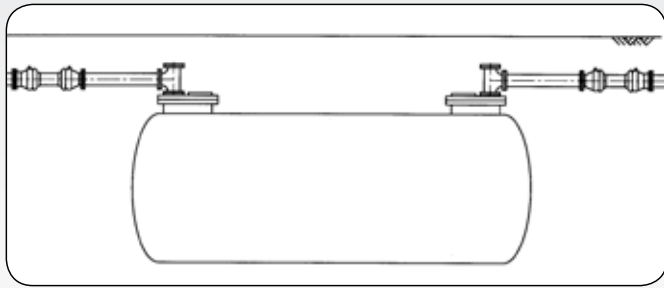

**BOUNDARY OF EARTH LAYER**

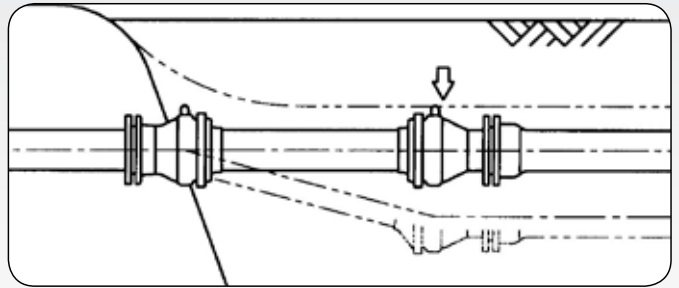

**LEADING INTO AND OUT OF A VALVE BOX.**

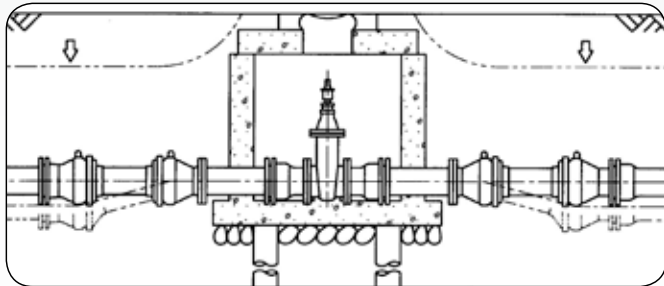

**ROAD CROSSING**

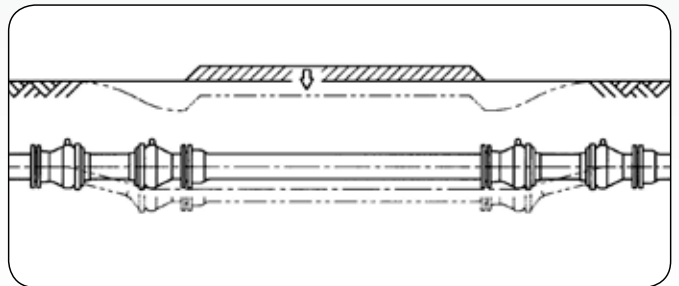

**SURROUNDING A STRUCTURE**

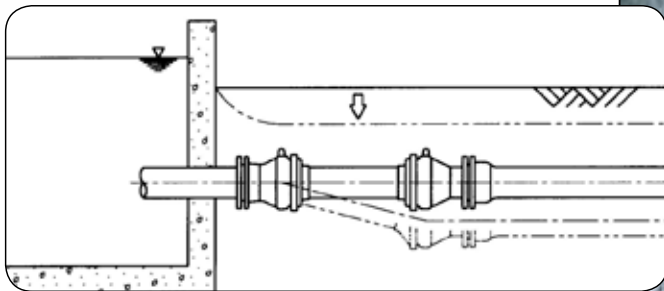

# PERFORMANCE TESTS



## 1. HORIZONTAL PRESSURE IN STRAIGHT AND OFFSET CONDITIONS

**Purpose:** To verify the integrity of the FJ Restraint in horizontal, straight and offset installations.

**Test Method:** Install the FJ Restraint into test equipment at horizontal and straight positions. Pressurize the FJ Restraint, inspecting for water leaks or other abnormal indications.



## 2. CYCLE TESTING OF EXPANSION AND OFFSET

**Purpose:** To verify the integrity of the FJ Restraint during repeated cycles of expansion, contraction, and offset.

**Test Method:** Install the FJ Restraint into the test equipment and repeat expansion, contraction, and offset for prescribed times while under water pressure.



## 3. RESTRAINING FORCE

**Purpose:** To verify the restraining force of the FJ Restraint.

**Test Method:** Install the FJ Restraint into the test apparatus and apply a tensile load equivalent to  $16,800d$  lbs.<sup>1</sup> at the ends.

<sup>1</sup> where “d” is in inches



## 4. WATER FLOW CHARACTERISTICS

**Purpose:** To examine the water flow inside the FJ Restraint.

**Test Method:** Use a clear acrylic FJ Restraint of 3 inch size to observe the water flow by visual inspection. Confirm that no water stagnation occurs inside of the FJ Restraint at straight and deflected conditions.



## 5. EARTHQUAKE RESISTANCE

**Purpose:** Test earthquake resistance of the FJ Restraint in underground conditions.

**Test Method:** Use equipment that approximately reproduces discontinuous earth, for example a boundary earth layer and connecting components between structures. Perform a shaking test to approximate the conditions of the Great Hanshin-Awaji Earthquake (that earthquake produced accelerations over  $818 \text{ cm/s}^2$ ). Confirm that no significant strain nor leakage is observed.

# INSTALLATION

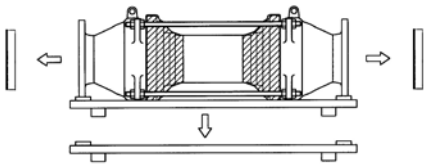

## STEP ONE

Remove the protective caps and packing material from the FJ Restraint. Remove straps attaching FJ Restraint to the shipping crate.

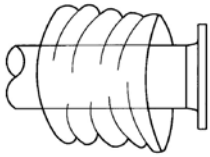

## STEP TWO

Slide the polyethylene sleeve over one pipe end to which the FJ Restraint will be connected.

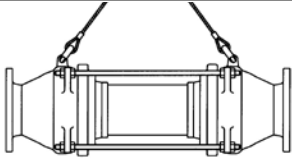

## STEP THREE

Using a suitable hoist, lift the FJ Restraint horizontally from the crate into position. **NOTE:** Use lifting slings and shackles to connect to the lifting eyes on the FJ Restraint. **DO NOT** lift the FJ Restraint by the tie rods.

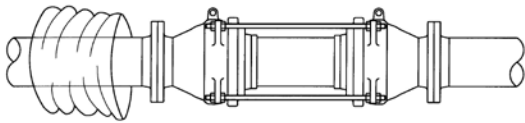

## STEP FOUR

Connect the ends of the FJ Restraint to the pipe ends.

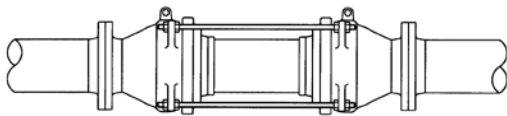

## STEP FIVE

Remove the tie rods. **NOTE:** The tie rods are provided to prevent change to the end-to-end dimensions during transportation and installation. If the FJ Restraint is used with the tie rods in place, it will neither bend or stretch as the product was intended. If a pressure test is to be performed before the site is backfilled, the tie rods must remain in the FJ Restraint until the test is completed.

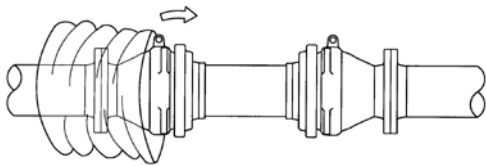

## STEP SIX

Pull the polyethylene sleeve over the FJ Restraint so that it completely covers the FJ Restraint from one pipe end to the other.

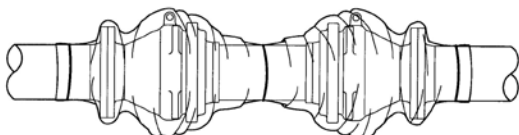

## STEP SEVEN

Fasten the polyethylene sleeve to the pipe and the FJ Restraint with the rubber bands. **NOTE:** Leave plenty of slack in the polyethylene sleeve to allow the FJ Restraint to bend and expand as intended.



**ROMAC INDUSTRIES, INC.**

Repair Clamps • Couplings • Expansion Joints • Pipe Restraint • Service Saddles  
Tapping Sleeves • Tapping Machines • Valve Insertion • Waterworks Tools

