

RFCA

Restrained Flange Coupling Adapter:

The simplest way to connect flanged fittings, valves, meters and other equipment to plain end pipe.

The flange connection is provided by a ductile iron flange body, complete with an o-ring which seals with the connecting flange. A second gasket seals the other end of the RFCA against the pipe wall.

The RFCA is "Stab-Fit." Installation is just a matter of inserting the pipe end, and tightening the bolts.

The restraint is provided by Romac's RomaGrip™. UL rated and FM approved, the RomaGrip™ restraint is the same field-tested restraint system in use in water systems around the world.

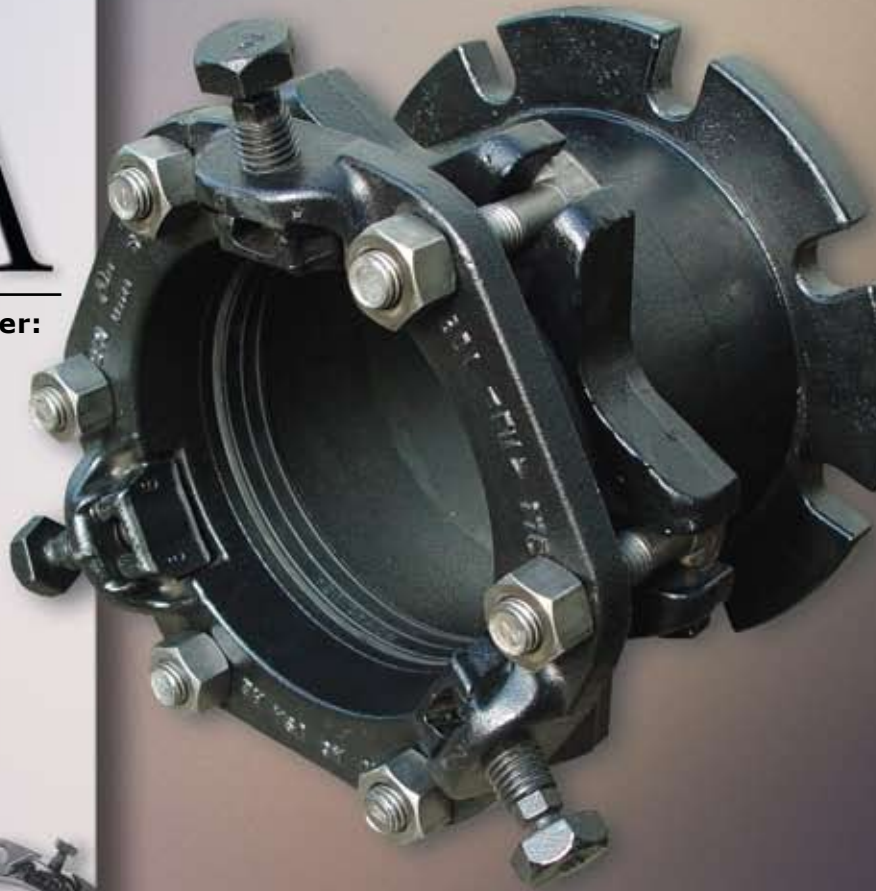

PVC - RFCA

The Romac also offers the PVC-RFCA for applications on PVC pipe.



ROMAC INDUSTRIES, INC.
www.romac.com
1 800 426 9341

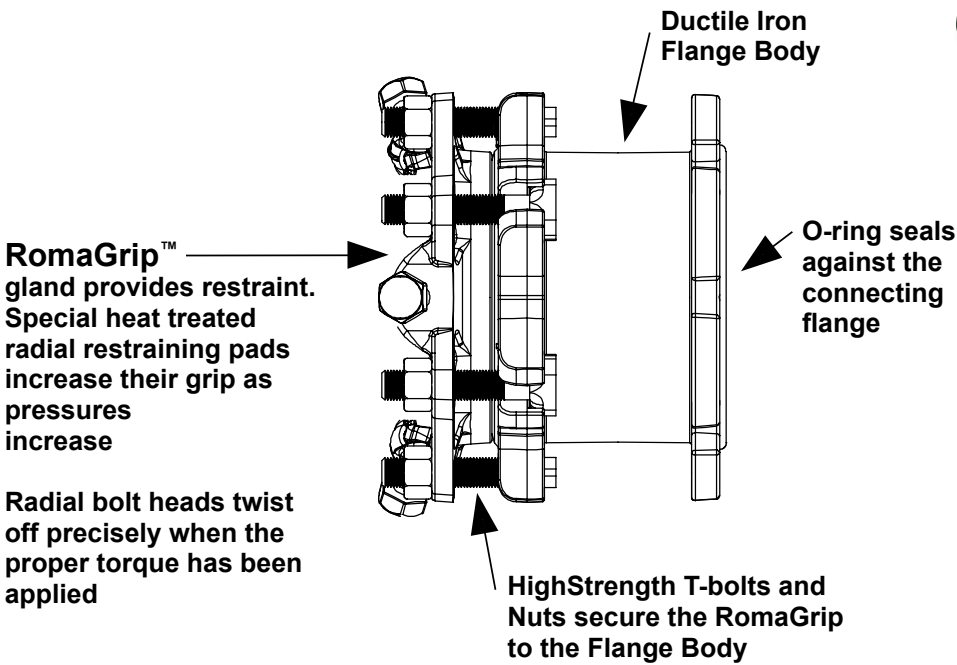

RFCA: For use on DI pipe and IPS size STD steel pipe 3" - 12".



PVC-RFCA: For use on PVC pipe.

RFCA MATERIALS

Gland and Flange Body: Ductile (nodular) iron, meeting or exceeding ASTM A 536, Grade 65-45-12.

Gaskets: Gaskets are made from virgin Styrene Butadiene Rubber (SBR) compounded for water and sewer service in accordance with ASTM D 2000 MBA 710. Other compounds available for petroleum, chemical, or high temperature service.

Restraining Bolt: 7/8 - 9 roll thread, Ductile (nodular) iron, meeting or exceeding ASTM A 536.

Restraining Lugs: Ductile (nodular) iron, meeting or exceeding ASTM A 536. Heat treated using a proprietary process.

T-bolts and Nuts: High strength low alloy steel T-head bolt. National coarse rolled thread and heavy hex nut. Steel meets AWWA C111 composition specifications. Stainless steel bolts and nuts available on request.

Coatings: Shop coat applied to cast parts for corrosion protection in transit. Fusion bonded epoxy available on request.

Flange: Compatible with ANSI Class 125 and 150 bolt circles.

This information is based on the best data available at the date printed, please check with Romac Engineering Department for any updates or changes.

NOM. PIPE SIZE	GASKET RANGE	WEIGHT (lbs.)	LENGTH
3"	3.50-3.96	25	8"
4"	4.50-4.80	31	9"
6"	6.63-6.90	41	9.25"
8"	8.63-9.05	53	9.25"
10"	10.75-11.10	83	10.25"
12"	12.75-13.20	110	10.25"
14"	15.30	170	11.7"
16"	17.40	200	11.7"
18"	19.50	217	11.8"
20"	21.60	256	11.8"
24"	25.80	305	12"

When ordering, please specify RFCA (for use on DI pipe and IPS size STD steel pipe 3" - 12"), or PVC-RFCA (for use on PVC pipe).