

1974



THE ORIGINAL DUCTILE IRON TWO-BOLT COUPLING

In 1974 Romac introduced our first two-bolt coupling, the Ringwej™. The patented Ringwej™ was available in two, four, six and eight inch sizes.

1974 Ringwej™ brochure. →



2009



MACRO™

ROMAC'S SECOND GENERATION TWO-BOLT EXTENDED RANGE COUPLING

• DESIGNED FOR STRENGTH AND LONG LIFE

- Ductile iron end-rings and center-ring have no welds.
- Heavy duty 5/8" stainless steel bolts with anti-galling protection.
- 304 stainless steel armor.
- Center ring is fusion bonded epoxy in accordance with AWWA C213 & NSF 61 certified.
- End rings are E-coated epoxy.

• EXTENDED RANGE

- With a range of up to 1.25 inches, the Macro™ can accommodate IPS through Class 200 A/C pipe.
- Insert an LR (Low-Range) Gasket and the Macro™ possesses a range of up to 2.10 inches and can cover smaller pipe diameters such as those for OD Steel and Sewer.

• EASY TO HANDLE AND INSTALL

- The built-in handle makes the Macro™ simple to carry and maneuver during installation.
- There is no need to disassemble the Macro™ during installation.
- Each end of the Macro™ tightens independently with a single bolt.
- If your work space requires it, the end rings can be clocked.
- The Macro™ is lighter than traditional wide range couplings.

• SEGMENTED END RINGS

- Segmented end rings compress the gaskets evenly around the entire pipe diameter.
- The end ring's integrated hinge allows the Macro™ to be easily disassembled if necessary.

• ALLOWS DEFLECTION

- The Macro™ can accommodate pipe deflection of up to 8 degrees (4 degrees on each end).

• CATHODIC PROTECTION

- The Macro™ can be ordered with an adapter / connection for cathodic protection if desired.

• ROMAC ORIGINAL DESIGN

- Romac manufactures the Macro™ in the U.S.A.
- Patents Pending.



MACRO DESIGN ADVANTAGES



RAW CENTER RING CASTING

ALL DUCTILE IRON

Poured in Romac's own foundry, the Macro's™ ductile iron end-rings and center-ring offer excellent corrosion resistance.

Ductile iron parts have different thicknesses along the cross-section, allowing the parts to concentrate strength where it needs to be.



FULLY ASSEMBLED MACRO™ WITH EPOXY COATED CENTER-RING AND E-COATED EPOXY END-RINGS.



SEGMENTED END-RINGS HAVE INTEGRATED HINGES.

SEGMENTED END RINGS

The Macro's™ segmented end-rings apply compression forces evenly around the gasket to provide a reliable seal around the entire pipe diameter.

The e-coated epoxy coating on the end-rings is highly resistant to abrasion and maintains corrosion resistance after installation.



DUAL GASKET SYSTEM NESTS ONE GASKET INSIDE THE OTHER.

NESTING DUAL GASKETS

The Macro's™ nesting dual gasket system accommodates a wide range of pipe diameters. Both gasket rings are used to couple smaller pipe sizes. The inner gasket can be removed to accommodate larger pipe diameters. If the inner gasket is removed it can be simply reinstalled if necessary. Gaskets are compounded for water and sewer service in accordance with ASTM D2000. NSF 61 certified gaskets and other compounds available on request.



MACRO'S INNER GASKET CAN BE REMOVED AND REINSTALLED



THE HANDLE IS BUILT INTO THE DUCTILE IRON CENTER RING

EASY TO INSTALL

Carrying and positioning the Macro™ is easy thanks to the center ring's integrated handle.

With only two bolts on the top of the Macro™, installation is a cinch.



CASTINGS:

ALL CAST COMPONENTS (END RINGS, CENTER RING, AND BOLT CAMS) ARE DUCTILE IRON, MEETING OR EXCEEDING THE REQUIREMENTS OF ASTM A 536, GRADE 65-45-12. END RINGS ARE SEGMENTED AND JOINED WITH INTEGRATED HINGES. CENTER RING IS CAST WITH INTEGRAL HANDLE FOR EASE OF ASSEMBLY.

GASKETS:

GASKETS FORMED FROM VIRGIN NITRILE BUTADIENE RUBBER (NBR) COMPOUNDED FOR WATER AND SEWER SERVICE IN ACCORDANCE WITH ASTM D2000. NSF 61 CERTIFIED GASKETS AND OTHER COMPOUNDS AVAILABLE ON REQUEST.

ARMORS:

HEAVY GAUGE 304 STAINLESS STEEL.

BOLTS & NUTS

5/8-11 UNC CARRIAGE HEAD BOLTS WITH HEAVY HEX NUTS, 304 STAINLESS STEEL (316 AVAILABLE UPON REQUEST). FASTENERS PROVIDED WITH ANTI-GALLING PROTECTION.

COATINGS:

CENTER RING FUSION BONDED EPOXY IN ACCORDANCE WITH AWWA C213 AND NSF 61 CERTIFIED. END RINGS E-COATED EPOXY.

PRESSURE:

WHEN PROPERLY INSTALLED, THE MACRO CAN BE USED AT WORKING PRESSURES UP TO 260 PSI.

INFORMATION CONTAINED IN THIS DOCUMENT IS SUBJECT TO CHANGE. CONTACT ROMAC INDUSTRIES FOR ANY UPDATES.

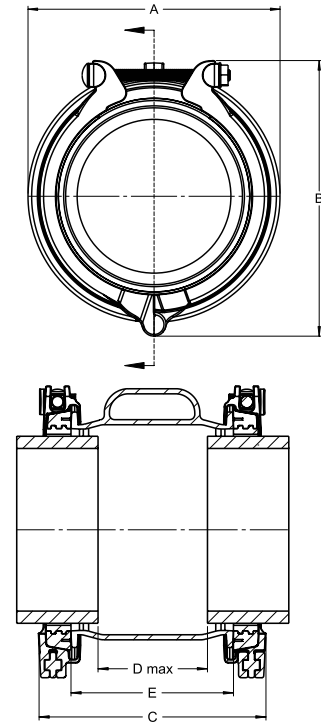

NOM. PIPE SIZE	OVERALL COUPLING RANGE		DIMENSIONS [INCHES]					APPROX. WT. [LBS.]	
	NESTING DUAL GASKETS		DIM. A WIDTH	DIM. B HEIGHT	DIM. C LENGTH	DIM. D GAP BETWEEN PIPE ENDS	DIM. E CENTER RING LENGTH		
4"	INNER GASKET RANGE 4.40 - 5.05	OUTER GASKET RANGE 4.95 - 5.60	4.40 - 5.60	8.96	10.18	11.19	6.00	8.00	28
6"	INNER GASKET RANGE 6.60 - 7.15	OUTER GASKET RANGE 7.10 - 7.60	6.60 - 7.60	10.96	12.18	11.19	6.00	8.00	34
8"	INNER GASKET RANGE 8.60 - 9.30	OUTER GASKET RANGE 9.10 - 9.75	8.60 - 9.75	13.11	14.33	11.19	6.00	8.00	36
10"	INNER GASKET RANGE 10.70 - 11.30	OUTER GASKET RANGE 11.25 - 11.90	10.70 - 11.90	15.26	16.48	11.19	6.00	8.00	57
10" XL	INNER GASKET RANGE 11.00 - 11.65	OUTER GASKET RANGE 11.55 - 12.20	11.00 - 12.20	15.56	16.78	11.19	6.00	8.00	57
12"	INNER GASKET RANGE 12.70 - 13.30	OUTER GASKET RANGE 13.15 - 13.80	12.70 - 13.80	17.16	18.38	11.19	6.00	8.00	62
12" XL	INNER GASKET RANGE 13.15 - 13.80	OUTER GASKET RANGE 13.75 - 14.40	13.15 - 14.40	17.76	18.98	11.19	6.00	8.00	62

OPTIONAL LR GASKET ADD-ON
 INTERCHANGEABLE INNER GASKET FOR SMALLER PIPE DIAMETERS. MAXIMUM WORKING PRESSURE FOR MACRO WITH LR GASKET IS 200 PSI. LR GASKETS ARE NOT COMPATIBLE WITH 10" XL OR 12" XL MACRO.

PIPE SIZE	RANGE	CATALOG NUMBER	WEIGHT (LBS.)
4"	3.50 - 4.30	BR26104LR	.68
6"	6.00 - 6.30	BR26106LR	.96
8"	8.00 - 8.40	BR26108LR	1.25
10"	10.00 - 10.50	BR26110LR	1.67
12"	12.00 - 12.50	BR26112LR	1.80

ADAPTED FOR CATHODIC PROTECTION ADD-ON



OPTIONAL MECHANICAL CONNECTION FOR ADDING CATHODIC PROTECTION SUCH AS AN ANODE (ROMAC DOES NOT SUPPLY ANODE). FOR MATERIAL SPECIFICATIONS OF MACRO WITH CATHODIC PROTECTION ADAPTER, SEE PRODUCT SUBMITTALS.